

**TRANSMISSION SECTION**

This service manual has been prepared to provide SUBARU service personnel with the necessary information and data for the correct maintenance and repair of SUBARU vehicles.

This manual includes the procedures for maintenance, disassembling, reassembling, inspection and adjustment of components and diagnostics for guidance of experienced mechanics.

Please peruse and utilize this manual fully to ensure complete repair work for satisfying our customers by keeping their vehicle in optimum condition. When replacement of parts during repair work is needed, be sure to use SUBARU genuine parts.

All information, illustration and specifications contained in this manual are based on the latest product information available at the time of publication approval.

**CONTROL SYSTEMS****CS****AUTOMATIC TRANSMISSION****AT****AUTOMATIC TRANSMISSION  
(DIAGNOSTICS)****AT****MANUAL TRANSMISSION AND  
DIFFERENTIAL****MT****CLUTCH SYSTEM****CL**

# AUTOMATIC TRANSMISSION

# AT

---

	<b>Page</b>
1. General Description .....	2
2. Automatic Transmission Fluid .....	9
3. Differential Gear Oil.....	11
4. Road Test.....	12
5. Stall Test .....	13
6. Time Lag Test .....	15
7. Line Pressure Test .....	16
8. Transfer Clutch Pressure Test .....	18
9. Automatic Transmission Assembly .....	19
10. Transmission Mounting System .....	25
11. Extension Case Oil Seal .....	27
12. Inhibitor Switch.....	28
13. Front Vehicle Speed Sensor .....	31
14. Rear Vehicle Speed Sensor.....	34
15. Torque Converter Turbine Speed Sensor .....	35
16. Control Valve Body .....	36
17. Shift Solenoids, Duty Solenoids and ATF Temperature Sensor .....	38
18. ATF Filter .....	43
19. Transmission Control Module (TCM) .....	44
20. ATF Cooler Pipe and Hose .....	45

# GENERAL DESCRIPTION

AUTOMATIC TRANSMISSION

## 1. General Description

### A: SPECIFICATIONS

#### 1. TORQUE CONVERTER CLUTCH

Model	1.6 L model	2.0 L model
Type	Symmetric, 3 element, single stage, 2 phase torque converter	
Stall torque ratio	2.2 — 2.4	2.0 — 2.2
Nominal diameter	236 mm (9.29 in)	246 mm (9.69 in)
Stall speed (at sea level)	2,200 — 2,700 rpm	2,000 — 2,500 rpm
One-way clutch	Sprague type one-way clutch	

#### 2. OIL PUMP

Type	Pracoid constant-displacement pump	
Driving method	Driven by engine	
Number of teeth	Inner rotor	9
	Outer rotor	10

#### 3. TRANSMISSION CONTROL ELEMENT

Type	4-forward, 1-reverse, double-row planetary gears
Multi-plate clutch	3 sets
Multi-plate brake	2 sets
One-way clutch (sprague type)	1 sets

#### 4. TRANSMISSION GEAR RATIO

	Gear ratio
1st	2.785
2nd	1.545
3rd	1.000
4th	0.694
Rev	2.272

#### 5. PLANETARY GEAR AND PLATE

	1.6 L model	2.0 L model
Tooth number of front sun gear	33	
Tooth number of front pinion	21	
Tooth number of front internal gear	75	
Tooth number of rear sun gear	42	
Tooth number of rear pinion	17	
Tooth number of rear internal gear	75	
Drive & driven plate number of high clutch	3	4
Drive & driven plate number of low clutch	4	
Drive & driven plate number of reverse clutch	1	2
Drive & driven plate number of 2-4 brake	2	3
Drive & driven plate number of low & reverse brake	4	

# GENERAL DESCRIPTION

AUTOMATIC TRANSMISSION

## 6. SELECTOR POSITION

P (Park)	Transmission in neutral, output member immovable, and engine start possible
R (Reverse)	Transmission in reverse for backing
N (Neutral)	Transmission in neutral and engine start possible
D (Drive)	Automatic gear change 1st ← → 2nd ← → 3rd ← → 4th
3 (3rd)	Automatic gear change 1st ← → 2nd ← → 3rd ← → 4th
2 (2nd)	Automatic gear change 1st ← → 2nd ← → 3rd ← → 4th
1 (1st)	1st gear locked (Deceleration possible 1st ← → 2nd ← → 3rd ← → 4th)
Control method	Hydraulic remote control

## 7. HYDRAULIC CONTROL AND LUBRICATION

Type	Electronic/hydraulic control [Four forward speed changes by electrical signals of vehicle speed and accelerator (throttle) opening]	
Fluid	Dexron III type Automatic transmission fluid	
Fluid capacity	1.6 L model	8.0 — 8.3 ℓ (8.5 — 8.8 US qt, 7.0 — 7.3 Imp qt)
	2.0 L model	8.4 — 8.7 ℓ (8.9 — 9.2 US qt, 7.4 — 7.7 Imp qt)
Lubrication system	Forced feed lubrication with oil pump	
Oil	Automatic transmission fluid (above mentioned)	

## 10.FINAL REDUCTION

Model	1.6 L model	2.0 L model																		
Front final gear ratio	4.444 (40/9)	4.111 (37/9)																		
Lubrication oil	<p>ITEM</p> <ul style="list-style-type: none"> <li>• Front differential gear oil</li> </ul> <p>API Classification</p> <p>GL - 5</p> <p>SAE Viscosity No. and Applicable Temperature</p> <table border="1"> <tr> <td>(°C)</td> <td>-30</td> <td>-26</td> <td>-15</td> <td>-5</td> <td>0</td> <td>15</td> <td>25</td> <td>30</td> </tr> <tr> <td>(°F)</td> <td>-22</td> <td>-15</td> <td>5</td> <td>23</td> <td>32</td> <td>59</td> <td>77</td> <td>86</td> </tr> </table> <p style="text-align: right;">H3M1235A</p>		(°C)	-30	-26	-15	-5	0	15	25	30	(°F)	-22	-15	5	23	32	59	77	86
(°C)	-30	-26	-15	-5	0	15	25	30												
(°F)	-22	-15	5	23	32	59	77	86												
Front differential oil capacity	1.2 ℓ (1.3 US qt, 1.1 Imp qt)																			

## 8. COOLING AND HARNESS

Model	1.6 L and 2.0 L models
Cooling system	Liquid-cooled cooler incorporated in radiator
ATF cooling system (Radiation capacity)	4.630 kW (3,981 kcal/h, 15,797 BTU/h)
Inhibitor switch	12 poles
Transmission harness	20 poles

## 9. TRANSFER

Model	2.0 L model
Transfer clutch	Hydraulic multi-plate clutch
Drive & driven plate number of transfer clutch	4
Control method	Electronic, hydraulic type
Lubricant	The same Automatic transmission fluid used in automatic transmission
1st reduction gear ratio	1.000 (53/53)

# GENERAL DESCRIPTION

## AUTOMATIC TRANSMISSION

### B: COMPONENT

#### NOTE:

For information about other transmission mounting components, refer to "AUTOMATIC TRANSMISSION" <Pub. No. G0853ZE> a separate publication.

### 1. TRANSMISSION MOUNTING

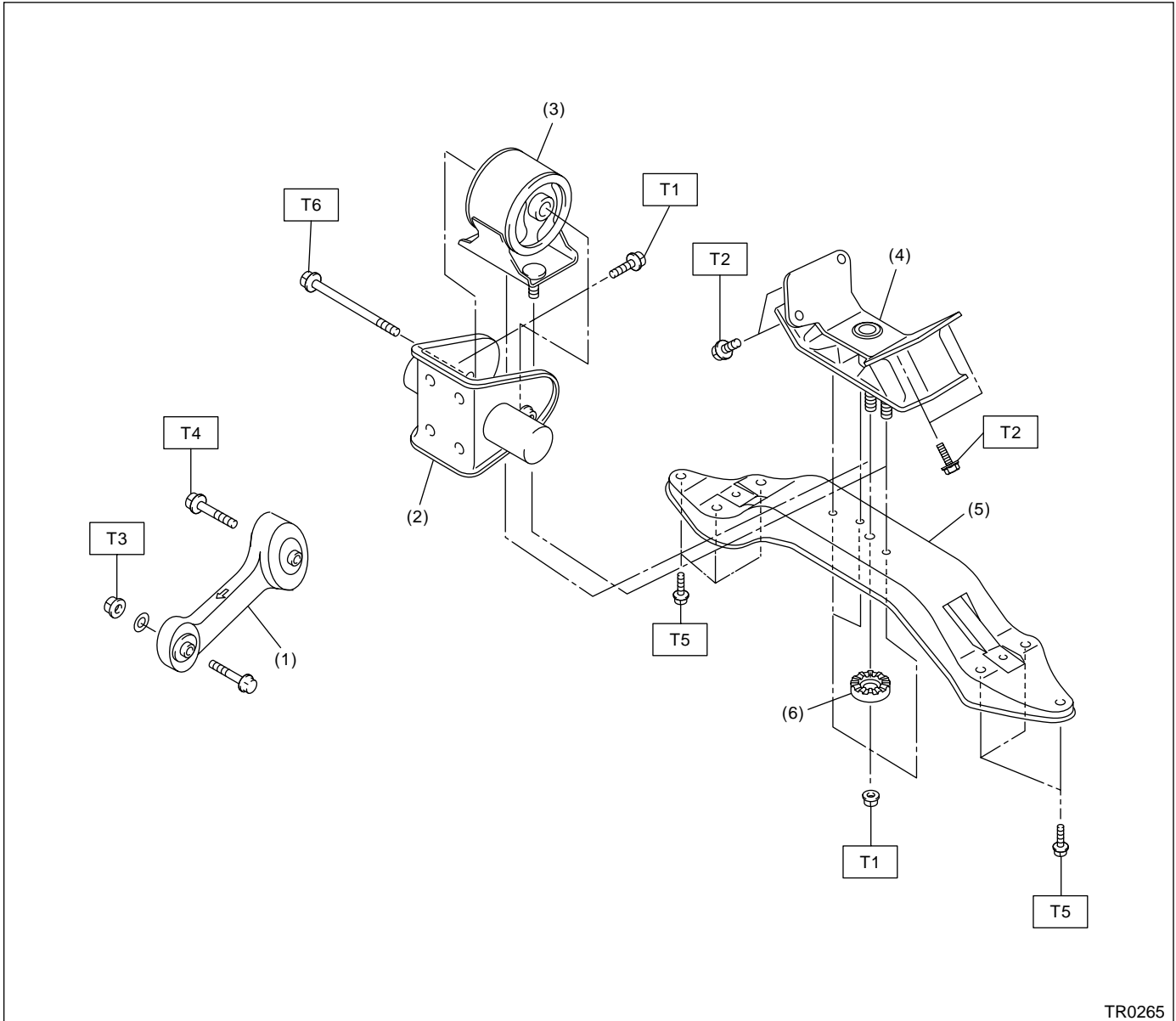

- (1) Pitching stopper
- (2) Rear bracket (FWD)
- (3) Rear cushion rubber (FWD)
- (4) Rear cushion rubber (AWD)
- (5) Crossmember
- (6) Stopper

**Tightening torque: N·m (kgf·m, ft·lb)**

**T1: 35 (3.6, 26)**

**T2: 39 (4.0, 29)**

**T3: 50 (5.1, 37)**

**T4: 58 (5.9, 43)**

**T5: 70 (7.1, 51)**

**T6: 123 (12.5, 90)**

# GENERAL DESCRIPTION

AUTOMATIC TRANSMISSION

## C: CAUTION

- Wear working clothing, including a cap, protective goggles, and protective shoes during operation.
- Remove contamination including dirt and corrosion before removal, installation, and disassembly.
- Keep the disassembled parts in order and protect them from dust or dirt.
- Until the oil pan is removed, do not place with the oil pan side facing up to prevent foreign matter from entering the valve body.
- Before removal, installation or disassembly, be sure to clarify the failure. Avoid unnecessary removal, installation, disassembly and replacement.
- When disassembling the case and other light alloy parts, use a plastic hammer to force it apart. Do not pry it apart with a screwdriver or other tool.
- Be careful not to burn your hands, because each part on the vehicle is hot after running.

- Use SUBARU genuine gear oil, grease etc. or the equivalent. Do not mix gear oil, grease etc. with that of another grade or from other manufacturers.
- Be sure to tighten fasteners including bolts and nuts to the specified torque.
- Place shop jacks or safety stands at the specified points.
- Apply gear oil onto sliding or revolution surfaces before installation.
- Replace deformed or otherwise damaged snap rings with new ones.
- Before installing O-rings or oil seals, apply sufficient amount of ATF fluid to avoid damage and deformation.
- Be careful not to incorrectly install or fail to install O-rings, snap rings and other such parts.
- Before securing a part on a vice, place cushioning material such as wood blocks, aluminum plate, or shop cloth between the part and the vice.
- Avoid damaging the mating surface of the case.
- Before applying sealant, completely remove the old seal.

## D: PREPARATION TOOL

### 1. SPECIAL TOOLS

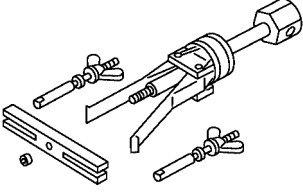
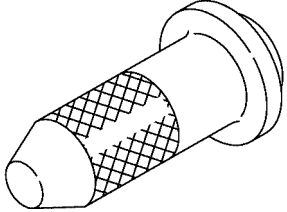
ILLUSTRATION	TOOL NUMBER	DESCRIPTION	REMARKS
 <p>B3M1977</p>	398527700	PULLER ASSY	Used for removing and installing extension case roller bearing.
 <p>B3M1972</p>	498057300	INSTALLER	Used for installing extension oil seal.

# GENERAL DESCRIPTION

## AUTOMATIC TRANSMISSION

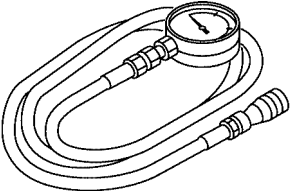
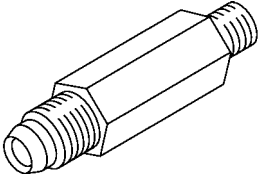
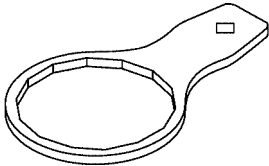
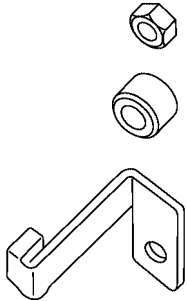
ILLUSTRATION	TOOL NUMBER	DESCRIPTION	REMARKS
 <p style="text-align: center;">B3M2040</p>	498575400	OIL PRESSURE GAUGE ASSY	Used for measuring oil pressure.
 <p style="text-align: center;">B3M2041</p>	498897200	ADAPTER	Used oil pump housing when measuring reverse clutch pressure and line pressure.
 <p style="text-align: center;">B3M2042</p>	498545400	FILTER WRENCH	Used for removing and installing ATF filter.
 <p style="text-align: center;">B3M2043</p>	498277200	STOPPER SET	Used for installing automatic transmission assembly to engine.

# GENERAL DESCRIPTION

AUTOMATIC TRANSMISSION

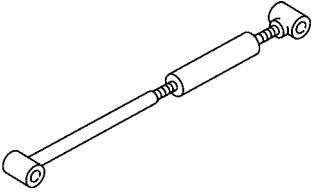
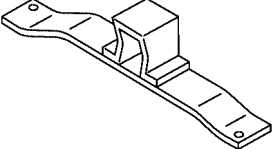
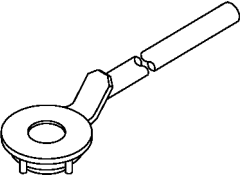
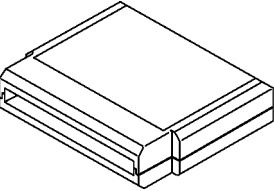
ILLUSTRATION	TOOL NUMBER	DESCRIPTION	REMARKS
 <p style="text-align: center;">B3M1976</p>	41099AA020	ENGINE SUPPORT	Used for supporting engine.
 <p style="text-align: center;">B3M1975</p>	41099AA010	ENGINE SUPPORT BRACKET	Used for supporting engine.
 <p style="text-align: center;">B2M4157</p>	499977300	CRANK PULLEY WRENCH	Used for stopping rotating of crankshaft pulley when loosening and tightening crankshaft pulley bolts.
 <p style="text-align: center;">B2M3876</p>	24082AA150	CARTRIDGE	Troubleshooting for electrical systems.



# GENERAL DESCRIPTION

## AUTOMATIC TRANSMISSION

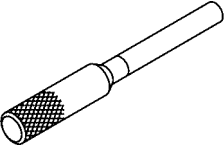
ILLUSTRATION	TOOL NUMBER	DESCRIPTION	REMARKS
 <p style="text-align: right;">B2M3877</p>	22771AA030	SELECT MONITOR KIT	Troubleshooting for electrical systems. <ul style="list-style-type: none"> <li>• English: 22771AA030 (Without printer)</li> <li>• German: 22771AA070 (Without printer)</li> <li>• French: 22771AA080 (Without printer)</li> <li>• Spanish: 22771AA090 (Without printer)</li> </ul>
 <p style="text-align: right;">B3M2008</p>	499267300	STOPPER PIN	Used for installing inhibitor switch.

## 2. GENERAL PURPOSE TOOLS

TOOL NAME	REMARKS
Circuit Tester	Used for measuring resistance, voltage and ampere.

## 2. Automatic Transmission Fluid

### A: INSPECTION

1) Check the level of the ATF.

(1) Raise ATF temperature to 60 to 80°C (140 to 176°F) from 40 to 60°C (104 to 140°F) (when cold) by driving a distance of 5 to 10 km (3 to 6 miles).

NOTE:

The level of ATF varies with fluid temperature. Pay attention to the fluid temperature when checking oil level.

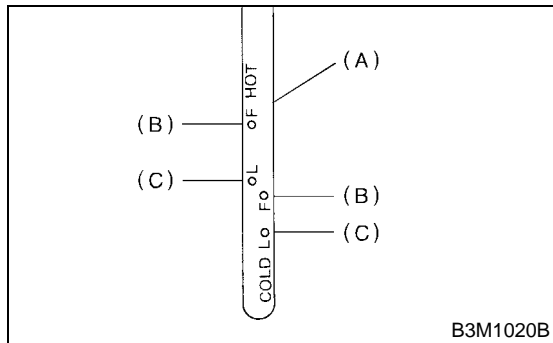

- (A) ATF level gauge
- (B) Upper level
- (C) Lower level

(2) Make sure the vehicle is level. After selecting all positions (P, R, N, D, 3, 2, 1), set the select lever in "P" range. Measure fluid level with the engine idling.

NOTE:

After running, idle the engine for one or two minutes before measurement.

(3) If the fluid level is below the center between upper and lower marks, add the recommended ATF until the fluid level is found within the specified range (above the center between upper and lower marks). When the transmission is hot, the level should be above the center of upper and lower marks, and when it is cold, the level should be found below the center of these two marks.

**CAUTION:**

- Use care not to exceed the upper limit level.
- ATF level varies with temperature. Remember that the addition of fluid to the upper limit mark when the transmission is cold will result in the overfilling of fluid.

(4) Fluid temperature rising speed

- By idling the engine

Time for temperature rise to 60°C (140°F) with atmospheric temperature of 0°C (32°F): More than 25 minutes

<Reference>

Time for temperature rise to 30°C (86°F) with atmospheric temperature of 0°C (32°F): Approx. 8 minutes

- By running the vehicle

Time for temperature rise to 60°C (140°F) with atmospheric temperature of 0°C (32°F): More than 10 minutes

(5) Method for checking fluid level upon delivery or at periodic inspection

Check fluid level after a warm-up run of approx. 10 minutes. During the warm-up period, the automatic transmission functions can also be checked.

2) Check the fluid for leaks.

Check for leaks in the transmission. If there are leaks, it is necessary to repair or replace gasket, oil seals, plugs or other parts.

### B: REPLACEMENT

1) Lift-up the vehicle.

2) Drain ATF completely.

**CAUTION:**

**Directly after the engine has been running, the ATF is hot. Be careful not to burn yourself.**

NOTE:

Tighten ATF drain plug after draining ATF.

**Tightening torque:**

**25 N·m (2.5 kgf·m, 18.1 ft·lb)**

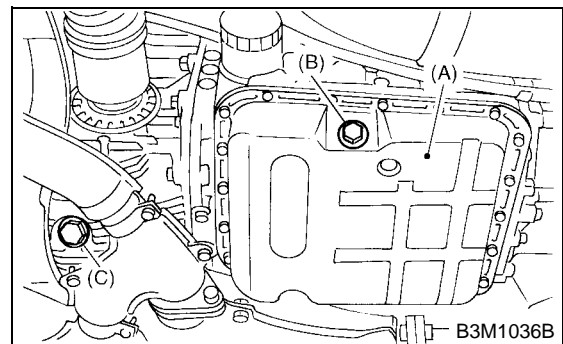

- (A) Oil pan
- (B) Drain plug
- (C) Differential oil drain plug

3) Lower the vehicle.

4) Pour ATF into the oil charge pipe.

**Recommended fluid:**

**Dexron III type automatic transmission fluid**

# AUTOMATIC TRANSMISSION FLUID

## AUTOMATIC TRANSMISSION

---

### **Capacity:**

***Fill the same amount of fluid drained from drain plug hole.***

### **Capacity when transmission is overhauled:**

#### **1.6 L model:**

**8.0 — 8.3 ℓ (8.5 — 8.8 US qt, 7.0 — 7.3 Imp qt)**

#### **2.0 L model:**

**8.4 — 8.7 ℓ (8.9 — 9.2 US qt, 7.4 — 7.7 Imp qt)**

5) Check the level and leaks of the ATF.

<Ref. to AT-9, REPLACEMENT, Automatic Transmission Fluid.>

## 3. Differential Gear Oil

### A: INSPECTION

- 1) Park vehicle on a level surface.
- 2) Remove oil level gauge and wipe it clean.
- 3) Reinsert the level gauge all the way. Be sure that the level gauge is correctly inserted and in the proper orientation.
- 4) Remove it again and note the reading. If the differential gear oil level is below the "L" line, add oil to bring the level up to the "F" line.
- 5) To prevent overfilling the differential gear oil, do not add oil above the "F" line.

- 3) Lower the vehicle.
- 4) Pour gear oil into the gauge hole.

**Recommended fluid:**

**Use GL-5 or equivalent.**

**Gear oil capacity:**

**1.2 ℓ (1.3 US qt, 1.1 Imp qt)**

- 5) Check the level of the differential gear oil.  
<Ref. to AT-11, INSPECTION, Differential Gear Oil.>

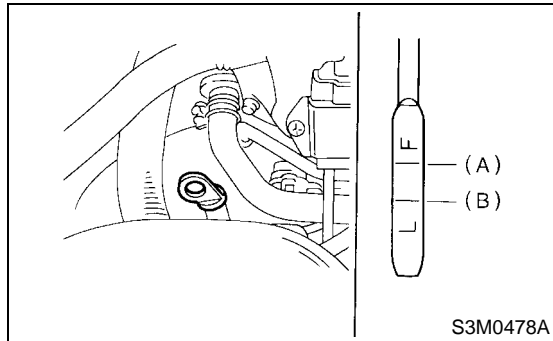

- (A) Upper level  
(B) Lower level

### B: REPLACEMENT

- 1) Lift-up the vehicle.
- 2) Drain differential gear oil completely.

**CAUTION:**

**Directly after the engine has been running, the differential gear oil is hot. Be careful not to burn yourself.**

**NOTE:**

Tighten differential gear oil drain plug after draining differential gear oil.

**Tightening torque:**

**44 N·m (4.5 kgf-m, 32.5 ft-lb)**

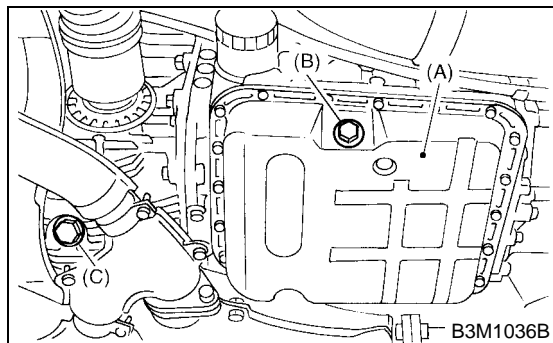

- (A) Oil pan  
(B) Drain plug  
(C) Differential oil drain plug

### 4. Road Test

#### A: INSPECTION

##### 1. GENERAL PRECAUTION

Road tests should be conducted to properly diagnose the condition of the automatic transmission.

##### CAUTION:

**When performing test, do not exceed posted speed limit.**

##### 2. D RANGE SHIFT FUNCTION

Check shifting between 1st ⇔ 2nd ⇔ 3rd ⇔ 4th while driving on normal city streets.

##### 3. D RANGE SHIFT SHOCK

Check the shock level when shifting up during normal driving.

##### 4. KICK-DOWN FUNCTION

Check kick-down for each gear. Also check the kick-down shock level.

##### 5. ENGINE BRAKE OPERATION

- Check the 3rd gear engine brake when shifting between D ⇔ 3rd range while driving in 4th gear of D range [50 to 60 km/h (31 to 37 MPH)].
- Check the 2nd gear engine brake when shifting between 3 ⇔ 2 range while driving in the 3 range 3rd gear [40 to 50 km/h (25 to 31 MPH)].
- Check the 1st gear engine brake when shifting between 2 ⇔ 1 range while driving in the 2 range 2nd gear [20 to 30 km/h (12 to 19 MPH)].

##### 6. LOCK-UP FUNCTION

Check that rpm does not change sharply when the axle pedal is lightly depressed when driving on flat roads at normal speed in the lock-up range.

##### 7. P RANGE OPERATION

Stop the vehicle on an uphill grade of 5% or more and shift to P range. Check that the vehicle does not move when the parking brake is released.

##### 8. UNUSUAL SOUNDS AND VIBRATION

Check for unusual sounds and vibration while driving and during shifting.

##### 9. CLIMBING CONTROL FUNCTION

- Check that gear remains in 3rd when going up a grade.
- Check that gear remains in 3rd when applying the brakes while going down a grade.

##### 10. OIL LEAKS

After the driving test, inspect for oil leaks.

## 5. Stall Test

### A: INSPECTION

#### 1. GENERAL INFORMATION

The stall test is of extreme importance in diagnosing the condition of the automatic transmission and the engine. It should be conducted to measure the engine stall speeds in R and 2 ranges.

Purposes of the stall test:

- 1) To check the operation of the automatic transmission clutch.
- 2) To check the operation of the torque converter clutch.
- 3) To check engine performance.

#### 2. TEST METHODS

1) Preparations before test:

- (1) Check that throttle valve opens fully.
- (2) Check that engine oil level is correct.
- (3) Check that coolant level is correct.
- (4) Check that ATF level is correct.
- (5) Check that differential gear oil level is correct.
- (6) Increase ATF temperature to 50 to 80°C (122 to 176°F) by idling the engine for approximately 30 minutes (with select lever set to "N" or "P").

2) Install an engine tachometer at a location visible from the driver's compartment and mark the stall speed range on the tachometer scale.

3) Place the wheel chocks at the front and rear of all wheels and engage the parking brake.

4) Move the manual linkage to ensure it operates properly, and shift the select lever to the 2 range.

5) While forcibly depressing the foot brake pedal, gradually depress the accelerator pedal until the engine operates at full throttle.

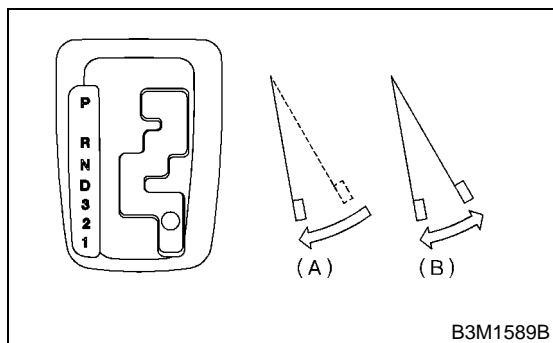

(A) Brake pedal

(B) Accelerator pedal

6) When the engine speed is stabilized, read that speed quickly and release the accelerator pedal.

7) Shift the select lever to Neutral, and cool down the engine by idling it for more than one minute.

8) Record the stall speed.

9) If stall speed in 2 range is higher than specifications, low clutch slipping and 2-4 brake slipping may occur. To identify it, conduct the same test as above in D range.

10) Perform the stall tests with the select lever in the R range.

NOTE:

- Do not continue the stall test for MORE THAN FIVE SECONDS at a time (from closed throttle, fully open throttle to stall speed reading). Failure to follow this instruction causes the engine oil and ATF to deteriorate and the clutch and brake to be adversely affected.

Be sure to cool down the engine for at least one minute after each stall test with the select lever set in the P or N range and with the idle speed lower than 1,200 rpm.

- If the stall speed is higher than the specified range, attempt to finish the stall test in as short a time as possible, in order to prevent the automatic transmission from sustaining damage.

**Stall speed (at sea level):**

**1.6 L model: 2,200 — 2,700**

**2.0 L model: 2,000 — 2,500**

# STALL TEST

AUTOMATIC TRANSMISSION

---

## 3. EVALUATION

Stall speed (at sea level)	Position	Cause
Less than specifications	2, R	<ul style="list-style-type: none"><li>• Throttle valve not fully open</li><li>• Erroneous engine operation</li><li>• Torque converter clutch's one-way clutch slipping</li></ul>
Greater than specifications	D	<ul style="list-style-type: none"><li>• Line pressure too low</li><li>• Low clutch slipping</li><li>• One-way clutch malfunctioning</li></ul>
	R	<ul style="list-style-type: none"><li>• Line pressure too low</li><li>• Reverse clutch slipping</li><li>• Low &amp; reverse brake slipping</li></ul>
	2	<ul style="list-style-type: none"><li>• Line pressure too low</li><li>• Low clutch slipping</li><li>• 2-4 brake slipping</li></ul>

## 6. Time Lag Test

### A: INSPECTION

#### 1. GENERAL INFORMATION

If the select lever is shifted while the engine is idling, there will be a certain time elapse or lag before the shock can be felt. This is used for checking the condition of the low clutch, reverse clutch, low & reverse brake and one-way clutch.

#### CAUTION:

- Perform the test at normal operation fluid temperature 60 to 80°C (140 to 176°F).
- Be sure to allow a one minute interval between tests.
- Make three measurements and take the average value.

#### 2. TEST METHODS

- 1) Fully apply the parking brake.
- 2) Start the engine.

Check idling speed (A/C OFF).

- 3) Shift the select lever from "N" to "D" range.

Using a stop watch, measure the time it takes from shifting the lever until the shock is felt.

Time lag: Less than 1.2 seconds

- 4) In same manner, measure the time lag for "N" → "R".

Time lag: Less than 1.5 seconds

#### 3. EVALUATION

- 1) If "N" → "D" time lag is longer than specified:
  - Line pressure too low
  - Low clutch worn
  - One-way clutch not operating properly
- 2) If "N" → "R" time lag is longer than specified:
  - Line pressure too low
  - Reverse clutch worn
  - Low & reverse brake worn



# LINE PRESSURE TEST

AUTOMATIC TRANSMISSION

## 7. Line Pressure Test

### A: MEASUREMENT

#### 1. GENERAL INFORMATION

If the clutch or the brake shows a sign of slippage or shifting sensation is not correct, the line pressure should be checked.

- Excessive shocks during upshifting or shifting takes place at a higher point than under normal circumstances, may be due to the line pressure being too high.
- Slippage or inability to operate the vehicle may, in most cases, be due to loss of oil pressure for the operation of the clutch, brake or control valve.

1) Line pressure measurement (under no load)

#### CAUTION:

- Before measuring line pressure, jack-up all wheels.
- Maintain temperature of ATF at approximately 50°C (122°F) during measurement. (ATF will reach the above temperature after idling the engine for approximately 30 minutes with select lever in "N" or "P".)

2) Line pressure measurement (under heavy load)

#### CAUTION:

- Before measuring line pressure, apply both foot and parking brakes with all wheels chocked (Same as for "stall" test conditions).
- Measure line pressure when select lever is in "R", "2" with engine under stall conditions.
- Measure line pressure within 5 seconds after shifting the select lever to each position. (If line pressure needs to be measured again, allow the engine to idle and then stop. Wait for at least one minute before measurement.)
- Maintain the temperature of ATF at approximately 50°C (122°F) during measurement. (ATF will reach the above temperature after idling the engine for approximately 30 minutes with the select lever in "N" or "P".)

#### 2. TEST METHODS

1) Temporarily attach the ST to a suitable place in the driver's compartment, remove the blind plug located in front of the toe board and pass the hose of the ST to the engine compartment.

ST 498575400 OIL PRESSURE GAUGE ASSY

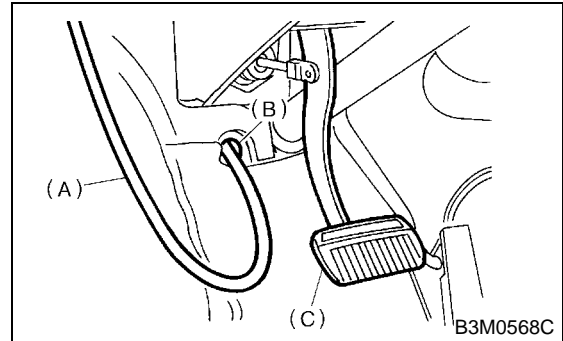

- (A) Pressure gauge hose
- (B) Hole in toe board (blank cap hole)
- (C) Brake pedal

2) Remove the test plug and install ST instead.

ST 498897200 OIL PRESSURE GAUGE ADAPTER

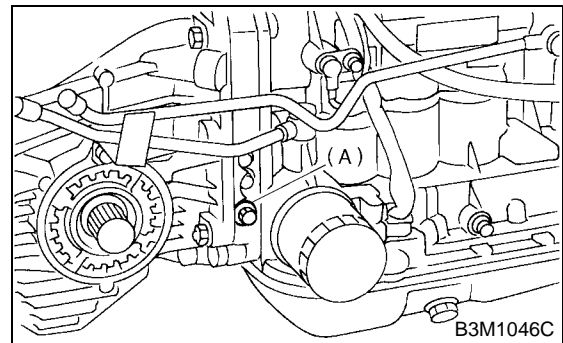

- (A) Test plug

3) Connect ST1 with ST2.

ST1 498897200 OIL PRESSURE GAUGE ADAPTER

ST2 498575400 OIL PRESSURE GAUGE ASSY

4) Check for duty ratio changes by opening and closing throttle valve using Subaru Select Monitor.

(1) Insert the cartridge to Subaru Select Monitor. <Ref. to AT-5, PREPARATION TOOL, General Description.>

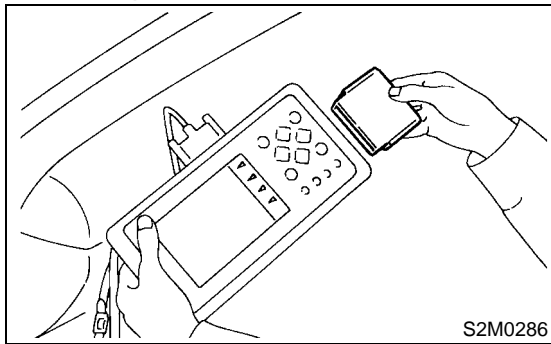

(2) Connect Subaru Select Monitor to data link connector.

5) Check line pressure in accordance with the following chart.

### 3. EVALUATION

Standard line pressure			
Range position	Line pressure duty ratio (%)	Throttle position	Line pressure kPa (kg/cm <sup>2</sup> , psi)
2	5	Full open	1,128 — 1,304 (11.5 — 13.3, 164 — 189)
R	5	Full open	1,520 — 1,716 (15.5 — 17.5, 220 — 249)
D	100	Full closed	304 — 412 (3.1 — 4.2, 44 — 60)

# TRANSFER CLUTCH PRESSURE TEST

AUTOMATIC TRANSMISSION

## 8. Transfer Clutch Pressure Test

### A: INSPECTION

#### 1. TEST METHODS

Check transfer clutch pressure in accordance with the following chart in the same manner as with line pressure.

ST 498897700 OIL PRESSURE ADAPTER SET

ST 498575400 OIL PRESSURE GAUGE ASSY

AWD mode: "D" range

FWD mode: "P" range, engine speed 2,000 rpm

#### CAUTION:

**Before setting in FWD mode, install spare fuse on FWD mode switch.**

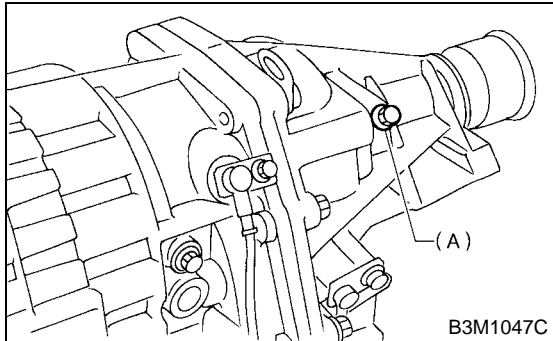

(A) Test plug

### 2. EVALUATION

#### NOTE:

If oil pressure is not produced or if it does not change in the AWD mode, the transfer duty solenoid or transfer valve assembly may be malfunctioning. If oil pressure is produced in the FWD mode, the problem is similar to that in the AWD mode.

Standard transfer clutch pressure kPa (kg/cm <sup>2</sup> , psi)			
Duty ratio (%)	Throttle position	AWD mode	FWD mode
5	Full closed	932 — 1,089 (9.5 — 11.1, 135 — 158)	—
60	2/3 throttle	216 — 294 (2.2 — 3.0, 31 — 43)	—
95	Full open	—	0 (0, 0)

## 9. Automatic Transmission Assembly

### A: REMOVAL

- 1) Set the vehicle on the lift.
- 2) Open front hood fully, and support with stay.
- 3) Disconnect battery ground terminal.
- 4) Remove air intake duct. <Ref. to IN(SOHC)-7, REMOVAL, Air Intake Duct.>
- 5) Remove air cleaner case. <Ref. to IN(SOHC)-6, REMOVAL, Air Cleaner Case.>
- 6) Remove air cleaner case stay.

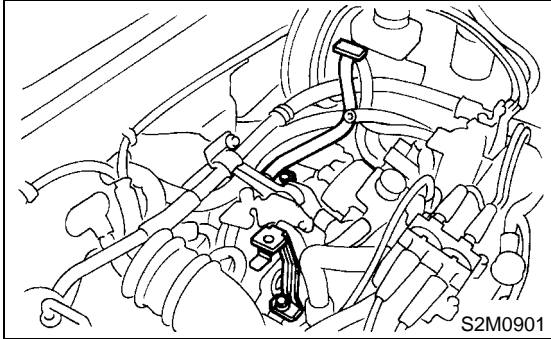

- 7) Remove front, center, rear exhaust pipe and muffler.

With OBD

<Ref. to EX(SOHC)-7, REMOVAL, Front Exhaust Pipe.>, <Ref. to EX(SOHC)-11, REMOVAL, Rear Exhaust Pipe.> and <Ref. to EX(SOHC)-12, REMOVAL, Muffler.>

Without OBD

<Ref. to EX(SOHCw/oOBD)-9, REMOVAL, Front Exhaust Pipe.>, <Ref. to EX(SOHCw/oOBD)-13, REMOVAL, Rear Exhaust Pipe.> and <Ref. to EX(SOHCw/oOBD)-14, REMOVAL, Muffler.>

- 8) Disconnect the following connectors.

- (1) Transmission harness connector

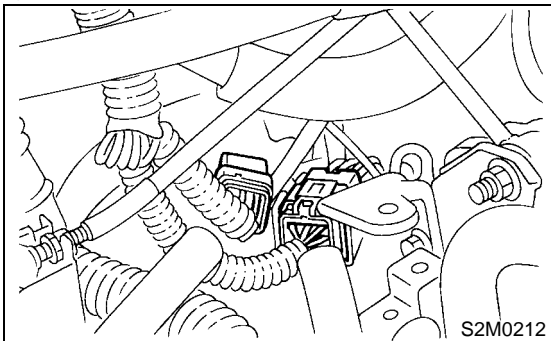

- (2) Transmission ground terminal

- 9) Remove starter. <Ref. to SC-5, REMOVAL, Starter.>

- 10) Remove pitching stopper.

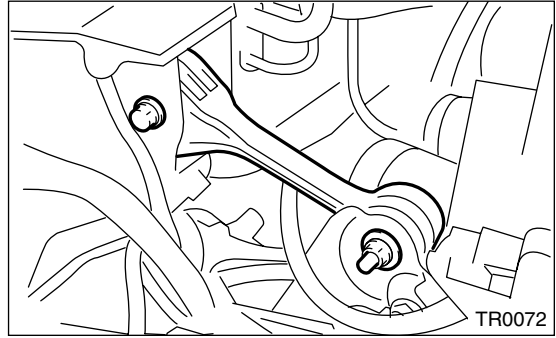

- 11) Separate torque converter clutch from drive plate.

- (1) Remove service hole plug.
- (2) Remove bolts which hold torque converter clutch to drive plate.
- (3) While rotating the engine, remove other bolts using ST.

**CAUTION:**

**Be careful not to drop bolts into torque converter clutch housing.**

ST 499977300 CRANK PULLEY WRENCH

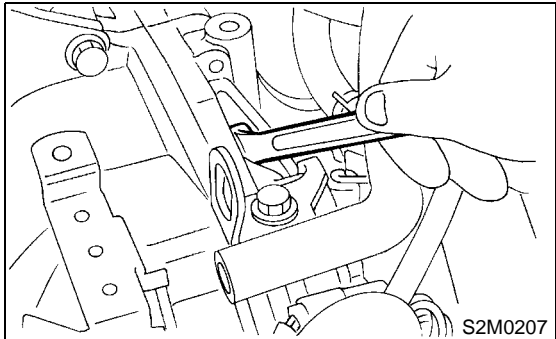

- 12) Install ST to torque converter clutch case.

ST 498277200 STOPPER SET

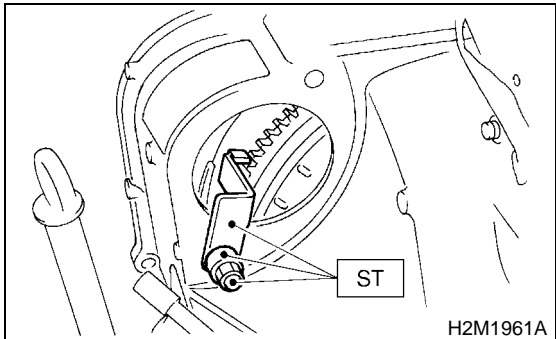

- 13) Remove ATF level gauge.

# AUTOMATIC TRANSMISSION ASSEMBLY

## AUTOMATIC TRANSMISSION

### CAUTION:

Plug opening to prevent entry of foreign particles into transmission fluid.

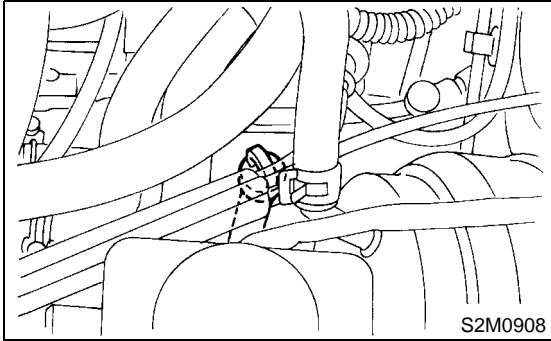

14) Set ST.

### NOTE:

Also is available Part No. 927670000.

ST 41099AA020 ENGINE SUPPORT ASSY

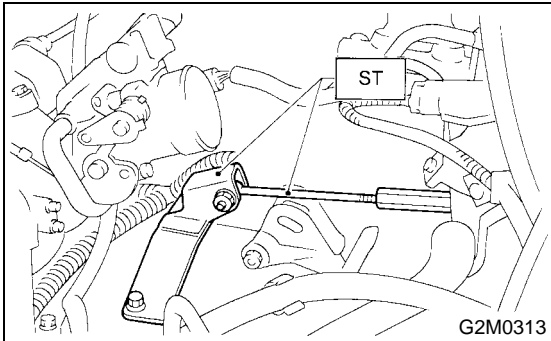

15) Remove bolt which holds right upper side of transmission to engine.

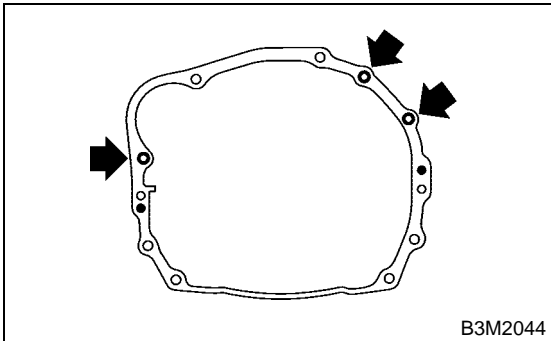

16) Lift-up the vehicle.

17) Remove under cover.

18) Remove heat shield cover.

19) Drain ATF to remove ATF drain plug.

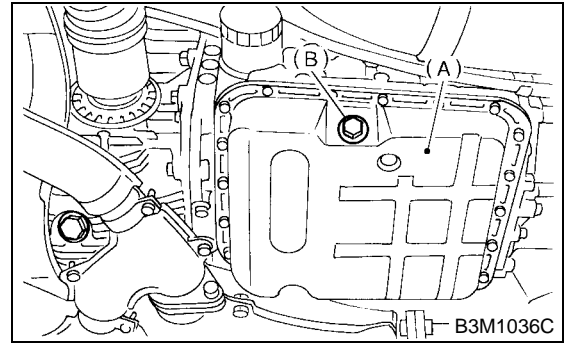

(A) Oil pan

(B) Drain plug

20) Disconnect ATF cooler hoses from pipes of transmission side, and remove ATF level gauge guide.

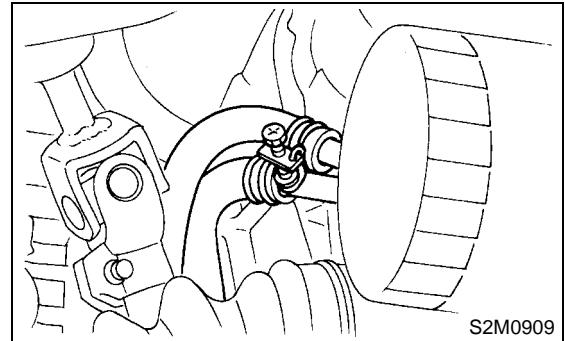

21) Remove propeller shaft.

<Ref. to DS-16, REMOVAL, Propeller Shaft.>

22) Remove shift select cable. <Ref. to CS-9, REMOVAL, Select Cable.>

23) Disconnect stabilizer link from transverse link.

24) Remove bolt securing ball joint of transverse link to housing.

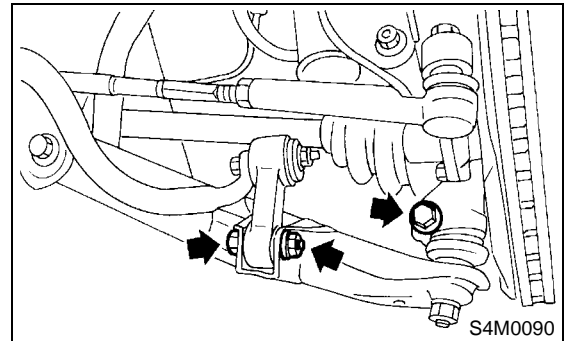

# AUTOMATIC TRANSMISSION ASSEMBLY

AUTOMATIC TRANSMISSION

25) Remove spring pins and separate front drive shafts from each side of the transmission.

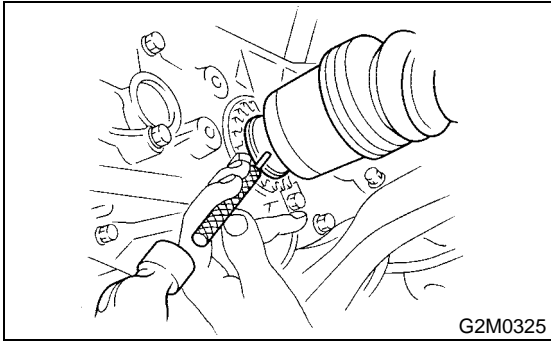

30) Separate transmission assembly and rear cushion rubber.

26) Remove nuts which hold lower side of transmission to engine.

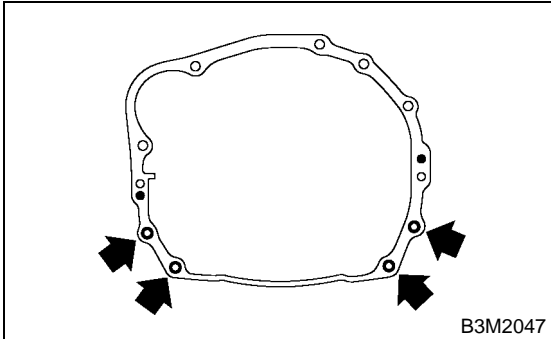

27) Place transmission jack under transmission.

### CAUTION:

- Make sure that the support plates of transmission jack don't touch the oil pan.

28) Remove transmission rear crossmember from vehicle.

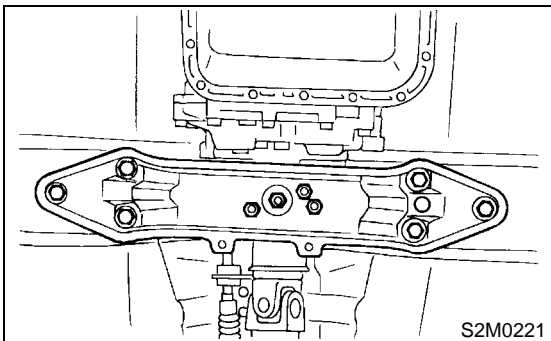

29) Remove transmission.

### CAUTION:

Move transmission and torque converter as a unit away from engine.

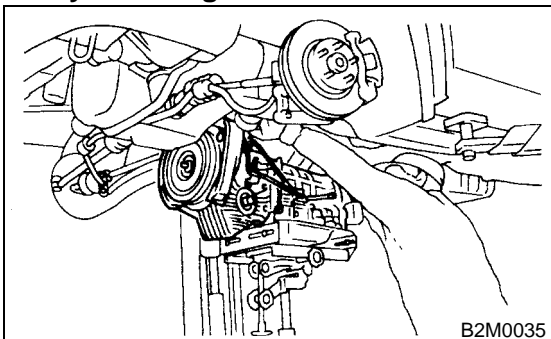

# AUTOMATIC TRANSMISSION ASSEMBLY

## AUTOMATIC TRANSMISSION

### B: INSTALLATION

1) Install rear cushion rubber to transmission assembly.

#### Tightening torque:

**1.6L MODEL:**

**123 N·m (12.5 kgf-m, 90 ft-lb)**

**2.0L MODEL:**

**38 N·m (3.9 kgf-m, 28 ft-lb)**

2) Install ST to torque converter clutch case.

ST 498277200 STOPPER SET

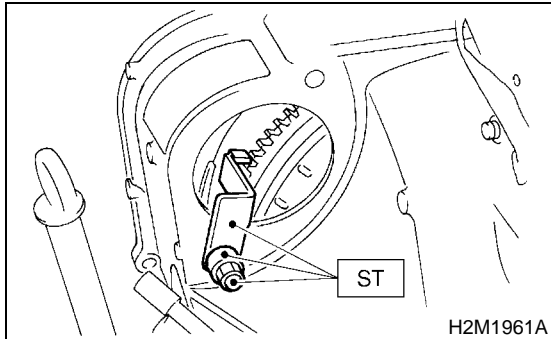

3) Install transmission onto engine.

(1) Gradually raise transmission with transmission jack.

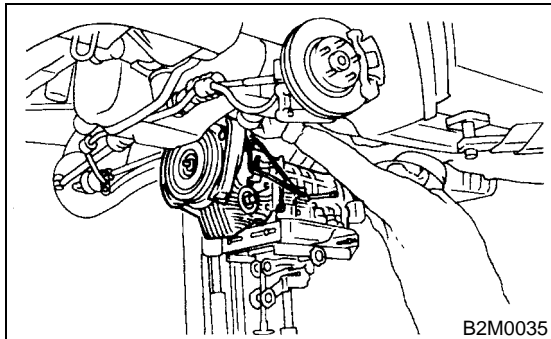

(2) Engage them at splines.

4) Install transmission rear crossmember.

#### Tightening torque:

**T1: 35 N·m (3.6 kgf-m, 26 ft-lb)**

**T2: 70 N·m (7.1 kgf-m, 51.4 ft-lb)**

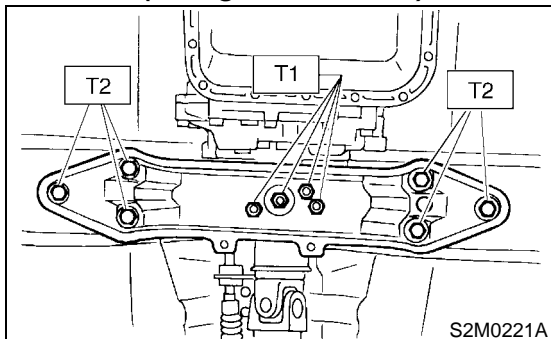

5) Take off transmission jack.

6) Tighten nuts and bolts which hold lower side of transmission to engine.

#### Tightening torque:

**50 N·m (5.1 kgf-m, 36.9 ft-lb)**

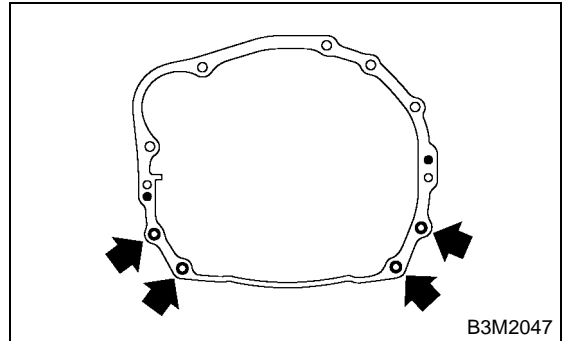

7) Lower the vehicle.

8) Connect engine and transmission.

(1) Remove ST from torque converter clutch case.

#### NOTE:

Be careful not to drop the ST into the torque converter clutch case when removing ST.

ST 498277200 STOPPER SET

(2) Install starter.

<Ref. to SC-6, INSTALLATION, Starter.>

(3) Tighten bolt which holds right upper side of transmission to engine.

#### Tightening torque:

**50 N·m (5.1 kgf-m, 36.9 ft-lb)**

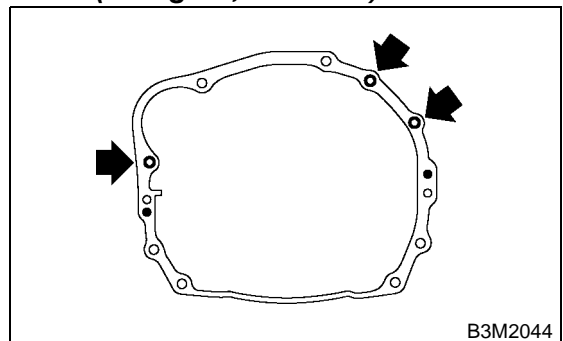

# AUTOMATIC TRANSMISSION ASSEMBLY

AUTOMATIC TRANSMISSION

- 9) Install torque converter clutch to drive plate.  
(1) Tighten bolts which hold torque converter clutch to drive plate.  
(2) Tighten other bolts while rotating the engine by using ST.

**CAUTION:**

Be careful not to drop bolts into torque converter clutch housing.

ST 499977300 CRANK PULLEY WRENCH

**Tightening torque:**

**25 N·m (2.5 kgf·m, 18.1 ft·lb)**

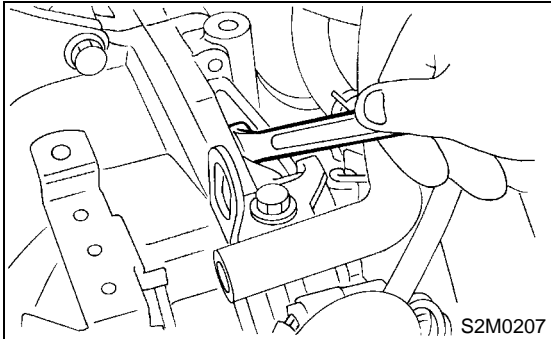

- (3) Clog plug onto service hole.  
10) Remove ST.

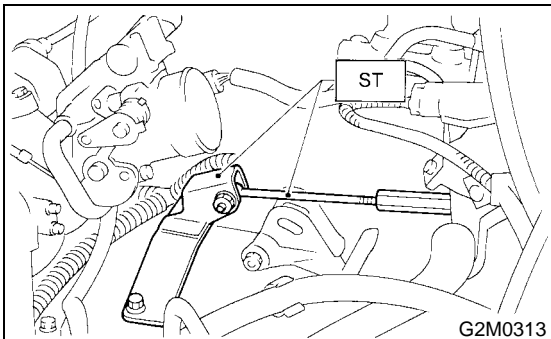

- 11) Install pitching stopper.

**Tightening torque:**

**T1: 50 N·m (5.1 kgf·m, 37 ft·lb)**

**T2: 58 N·m (5.9 kgf·m, 43 ft·lb)**

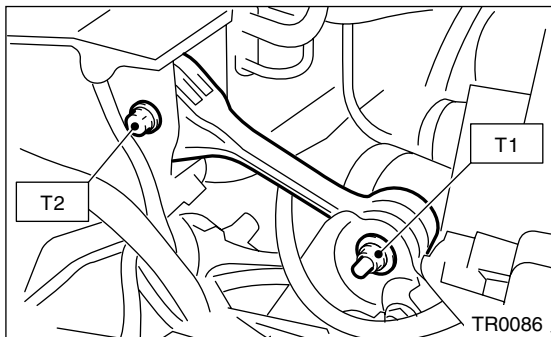

- 12) Lift-up the vehicle.  
Install front drive shafts into transmission.

- (1) Lift-up the vehicle.  
(2) Install front drive shaft into transmission.  
(3) Drive spring pin into chamfered hole of drive shaft.

**CAUTION:**

Always use a new spring pin.

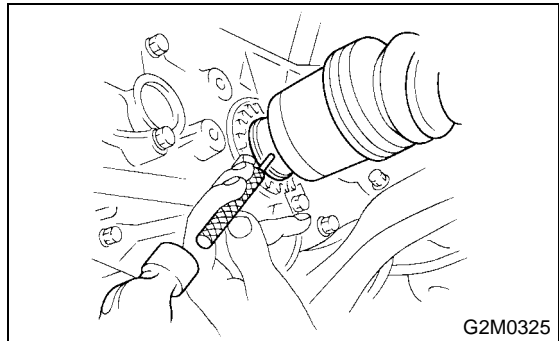

- 13) Install ball joint into housing.  
14) Connect stabilizer link to transverse link, and temporarily tighten bolts.

**CAUTION:**

Discard loosened self-locking nut and replace with a new one.

**Tightening torque:**

**T1: 30 N·m (3.1 kgf·m, 22.4 ft·lb)**

**T2: 50 N·m (5.1 kgf·m, 37 ft·lb)**

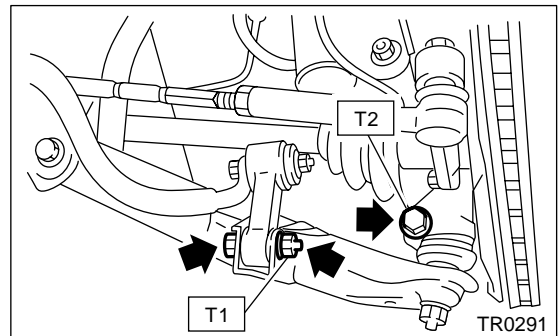

- 15) Install shift select cable onto select lever.  
<Ref. to CS-10, INSTALLATION, Select Cable.>  
16) Install ATF level gauge guide, and connect ATF cooler hoses to pipe.

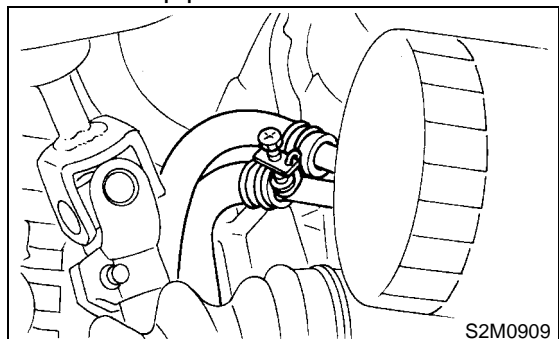

- 17) Install propeller shaft.  
<Ref. to DS-17, INSTALLATION, Propeller Shaft.>



# AUTOMATIC TRANSMISSION ASSEMBLY

## AUTOMATIC TRANSMISSION

- 18) Install heat shield cover.
- 19) Install front, center, rear exhaust pipes and muffler.

With OBD

<Ref. to EX(SOHC)-8, INSTALLATION, Front Exhaust Pipe.>, <Ref. to EX(SOHC)-11, INSTALLATION, Rear Exhaust Pipe.> and <Ref. to EX(SOHC)-12, INSTALLATION, Muffler.>

Without OBD

<Ref. to EX(SOHCw/oOBD)-10, INSTALLATION, Front Exhaust Pipe.>, <Ref. to EX(SOHCw/oOBD)-13, INSTALLATION, Rear Exhaust Pipe.> and <Ref. to EX(SOHCw/oOBD)-14, INSTALLATION, Muffler.>

- 20) Install under cover.
- 21) Lower the vehicle.
- 22) Install ATF level gauge.

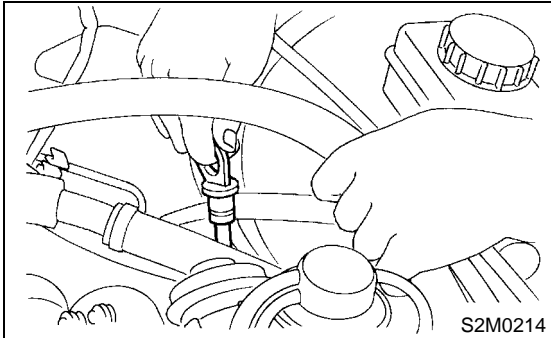

- 23) Connect the following connectors.
  - (1) Transmission harness connectors
  - (2) Transmission ground terminal
- 24) Connect the following cables.
  - (1) Cruise control cable (With cruise control vehicles)
- 25) Install air cleaner case stay.

### **Tightening torque:**

**16 N·m (1.6 kgf-m, 11.6 ft-lb)**

- 26) Install air cleaner case. <Ref. to IN(SOHC)-7, INSTALLATION, Air Intake Duct.>
- 27) Install air intake duct. <Ref. to IN(SOHC)-7, INSTALLATION, Air Intake Duct.>
- 28) Connect battery ground cable.
- 29) Fill ATF up to the middle of the "COLD" side on level gauge by using the gauge hole.

### **Recommended fluid:**

**Dexron III type automatic transmission fluid**

### **Fluid capacity:**

**1.6 L model:**

**8.0 — 8.3 ℓ (8.5 — 8.8 US qt, 7.0 — 7.3 Imp qt)**

**2.0 L model:**

**8.4 — 8.7 ℓ (8.9 — 9.2 USqt, 7.4 — 8.4 Imp qt)**

- 30) Take off vehicle from lift arms.

- 31) Check select lever operation.  
<Ref. to AT-28, INSPECTION, Inhibitor Switch.>
- 32) Check the ATF level. <Ref. to AT-9, Automatic Transmission Fluid.>
- 33) Check the vehicle on the road tester.  
<Ref. to AT-12, Road Test.>

## 10. Transmission Mounting System

### A: REMOVAL

#### 1. PITCHING STOPPER

- 1) Disconnect battery ground terminal.
- 2) Remove the air intake duct. <Ref. to IN(SOHC)-7, REMOVAL, Air Intake Duct.>
- 3) Remove the air cleaner case. <Ref. to IN(SOHC)-6, REMOVAL, Air Cleaner Case.>
- 4) Remove the pitching stopper.

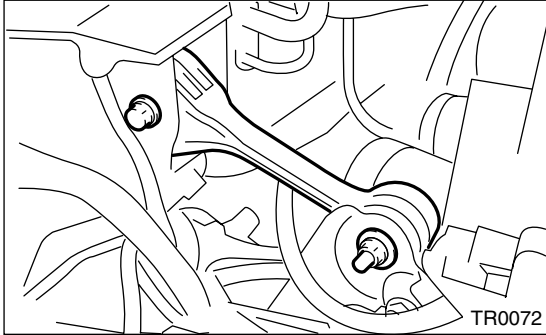

#### 2. CROSSMEMBER AND CUSHION RUBBER

- 1) Disconnect battery ground terminal.
- 2) Jack-up vehicle and support it with sturdy racks.
- 3) Remove the front, center, rear exhaust pipes and muffler.

With OBD

<Ref. to EX(SOHC)-7, REMOVAL, Front Exhaust Pipe.>, <Ref. to EX(SOHC)-11, REMOVAL, Rear Exhaust Pipe.> and <Ref. to EX(SOHC)-12, REMOVAL, Muffler.>

Without OBD

<Ref. to EX(SOHCw/oOBD)-9, REMOVAL, Front Exhaust Pipe.>, <Ref. to EX(SOHCw/oOBD)-13, REMOVAL, Rear Exhaust Pipe.> and <Ref. to EX(SOHCw/oOBD)-14, REMOVAL, Muffler.>

#### CAUTION:

**When removing exhaust pipes, be careful each exhaust pipe does not drop out.**

- 4) Remove the heat shield cover.
- 5) Set the transmission jack under the transmission.

#### CAUTION:

- Make sure that the support plates of transmission jack don't touch the oil pan.

- 6) Remove the crossmember.

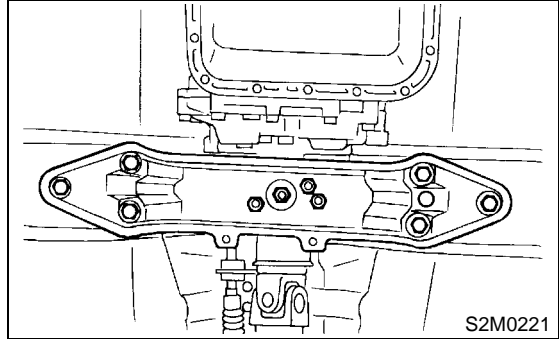

- 7) Remove the rear cushion rubber.

### B: INSTALLATION

#### 1. PITCHING STOPPER

- 1) Install the pitching stopper.

#### Tightening torque:

**T1: 50 N·m (5.1 kgf-m, 37 ft-lb)**

**T2: 58 N·m (5.9 kgf-m, 43 ft-lb)**

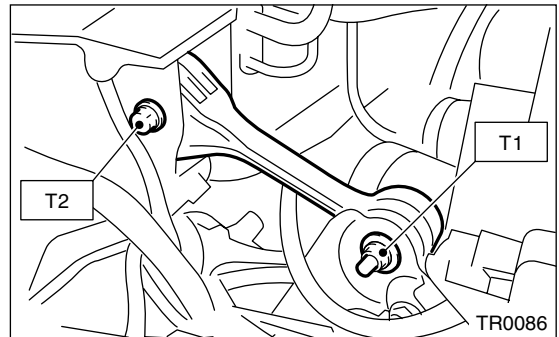

- 2) Install the air intake duct and cleaner case.

# TRANSMISSION MOUNTING SYSTEM

## AUTOMATIC TRANSMISSION

### 2. CROSSMEMBER AND CUSHION RUBBER

1) Install the rear cushion rubber.

#### **Tightening torque:**

**1.6 L model:**

**123 N·m (12.5 kgf-m, 90 ft-lb)**

**2.0 L model:**

**38 N·m (3.9 kgf-m, 28 ft-lb)**

2) Install the crossmember.

#### **Tightening torque:**

**T1: 35 N·m (3.6 kgf-m, 26 ft-lb)**

**T2: 70 N·m (7.1 kgf-m, 51.4 ft-lb)**

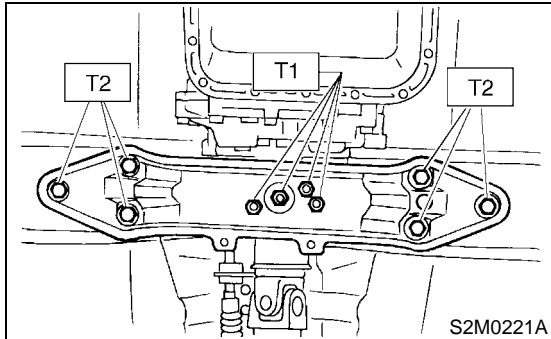

3) Remove the transmission jack.

4) Install the heat shield cover.

5) Install the front, center, rear exhaust pipes and the muffler.

With OBD

<Ref. to EX(SOHC)-8, INSTALLATION, Front Exhaust Pipe.>, <Ref. to EX(SOHC)-11, INSTALLATION, Rear Exhaust Pipe.> and <Ref. to EX(SOHC)-12, INSTALLATION, Muffler.>

Without OBD

<Ref. to EX(SOHCw/oOBD)-10, INSTALLATION, Front Exhaust Pipe.>, <Ref. to EX(SOHCw/oOBD)-13, INSTALLATION, Rear Exhaust Pipe.> and <Ref. to EX(SOHCw/oOBD)-14, INSTALLATION, Muffler.>

### C: INSPECTION

Repair or replace parts if the results of the inspection below are not satisfactory.

#### 1. PITCHING STOPPER

Make sure that the pitching stopper is not bent or damaged. Make sure that the rubber is not stiff, cracked, or otherwise damaged.

#### 2. CROSSMEMBER AND CUSHION RUBBER

Make sure that the crossmember is not bent or damaged. Make sure that the cushion rubber is not stiff, cracked, or otherwise damaged.

## 11. Extension Case Oil Seal

### A: INSPECTION

Make sure ATF does not leak from the joint of the transmission and propeller shaft. If so, replace oil seal. <Ref. to AT-27, REPLACEMENT, Extension Case Oil Seal.>

### B: REPLACEMENT

- 1) Set the vehicle on the lift.
- 2) Disconnect battery ground terminal.
- 3) Lift up the vehicle.
- 4) Clean transmission exterior.
- 5) Drain ATF completely.

#### NOTE:

Tighten ATF drain plug after draining ATF.

#### Tightening torque:

**25 N·m (2.5 kgf·m, 18.1 ft·lb)**

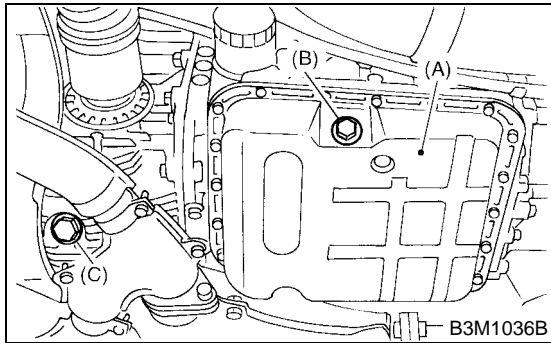

- (A) Oil pan
- (B) Drain plug
- (C) Differential oil drain plug

- 6) Remove the rear exhaust pipe and muffler.

With OBD

<Ref. to EX(SOHC)-11, REMOVAL, Rear Exhaust Pipe.> and <Ref. to EX(SOHC)-12, REMOVAL, Muffler.>

Without OBD

<Ref. to EX(SOHCw/oOBD)-13, REMOVAL, Rear Exhaust Pipe.> and <Ref. to EX(SOHCw/oOBD)-14, REMOVAL, Muffler.>

- 7) Remove the heat shield cover.

- 8) Remove the propeller shaft. <Ref. to DS-16, REMOVAL, Propeller Shaft.>

- 9) Using ST, remove the oil seal.

ST 398527700 PULLER ASSY

- 10) Using ST, install the oil seal.

ST 498057300 INSTALLER

- 11) Install the propeller shaft. <Ref. to DS-17, INSTALLATION, Propeller Shaft.>

- 12) Install the heat shield cover.

- 13) Install the rear exhaust pipe and muffler.

With OBD

<Ref. to EX(SOHC)-11, INSTALLATION, Rear Exhaust Pipe.> and <Ref. to EX(SOHC)-12, INSTALLATION, Muffler.>

Without OBD

<Ref. to EX(SOHCw/oOBD)-13, INSTALLATION, Rear Exhaust Pipe.> and <Ref. to EX(SOHCw/oOBD)-14, INSTALLATION, Muffler.>

- 14) Pour ATF and check the ATF level. <Ref. to AT-9, Automatic Transmission Fluid.>

# INHIBITOR SWITCH

AUTOMATIC TRANSMISSION

## 12. Inhibitor Switch

### A: INSPECTION

When driving condition or starter motor operation is erroneous, first check the shift linkage for improper operation. If the shift linkage is functioning properly, check the inhibitor switch.

- 1) Disconnect inhibitor switch connector.
- 2) Check continuity in inhibitor switch circuits with select lever moved to each position.

#### CAUTION:

**Also check that continuity in ignition circuit does not exist when select lever is in R, D, 3, 2 and 1 ranges.**

#### NOTE:

If inhibitor switch is inoperative, check for poor contact of connector on transmission side.

	Position	Pin No.
Signal sent to TCM	P	4 — 3
	R	4 — 2
	N	4 — 1
	D	4 — 8
	3	4 — 7
	2	4 — 6
	1	4 — 5
Starter circuit	P/N	12 — 11
Back-up light circuit	R	10 — 9

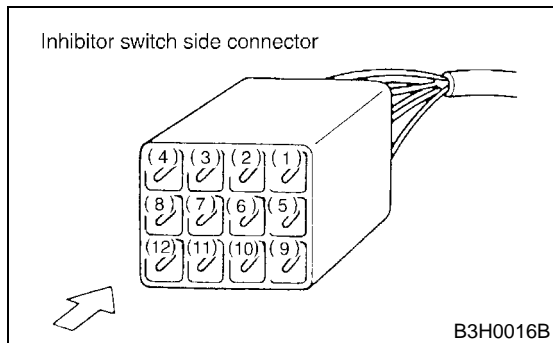

- 3) Check if there is continuity at equal points when the select lever is turned 1.5° in both directions from the N range.

If there is continuity in one direction and the continuity in the other or if there is continuity at unequal points, adjust the inhibitor switch. <Ref. to AT-28, ADJUSTMENT, Inhibitor Switch.>

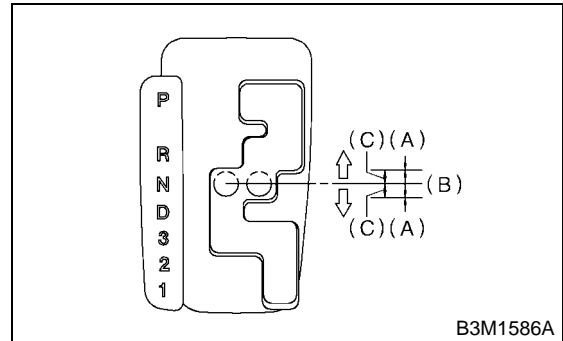

- (A) Continuity does not exist.
- (B) Continuity exists.
- (C) 1.5°

- 4) Repeat the above checks. If there are abnormalities, adjust the select cable. <Ref. to CS-10, ADJUSTMENT, Select Cable.>

### B: ADJUSTMENT

- 1) Shift the select lever to the N range.
- 2) Loosen the three inhibitor switch securing bolts.
- 3) Insert ST as vertical as possible into the holes in the inhibitor switch lever and switch body.  
ST 499267300 STOPPER PIN

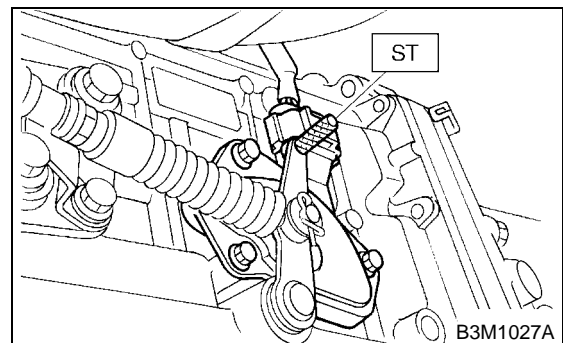

- 4) Tighten the three inhibitor switch bolts.

#### Tightening torque:

**3.4 N·m (0.35 kgf·m, 2.5 ft·lb)**

- 5) Repeat the above checks. If the inhibitor switch is determined to be "faulty", replace it.

## C: REMOVAL

- 1) Set up the vehicle on the lift.
- 2) Move select lever to neutral position.
- 3) Remove air intake duct and cleaner case.
- 4) Disconnect inhibitor switch connector.

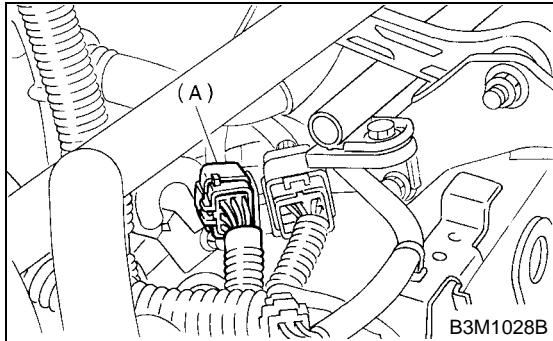

(A) Inhibitor switch

- 5) Remove inhibitor switch connector from stay.
  - 6) Lift-up the vehicle.
  - 7) Remove front exhaust pipe with center exhaust pipe.
- With OBD  
 <Ref. to EX(SOHC)-7, REMOVAL, Front Exhaust Pipe.>
- Without OBD  
 <Ref. to EX(SOHCw/oOBD)-9, REMOVAL, Front Exhaust Pipe.>
- 8) Remove snap pin from range select lever.

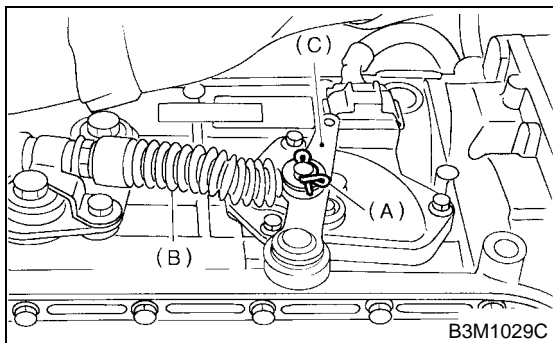

(A) Snap pin  
 (B) Select cable  
 (C) Range select lever

- 9) Remove plate assembly from transmission case.

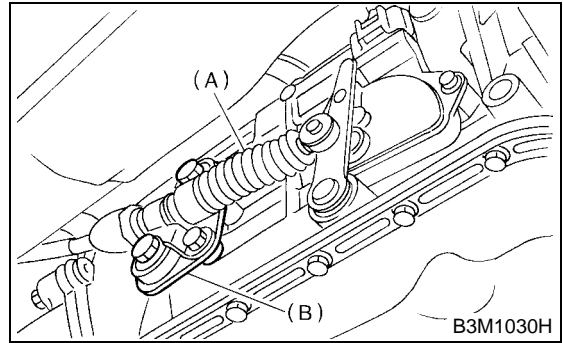

(A) Select cable  
 (B) Plate ASSY

- 10) Remove bolts.

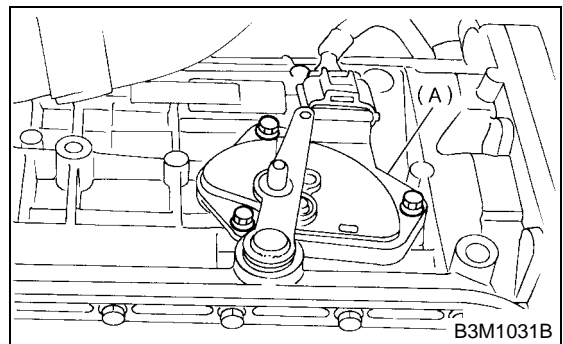

(A) Inhibitor switch

- 11) Move range select lever to parking position (left side).

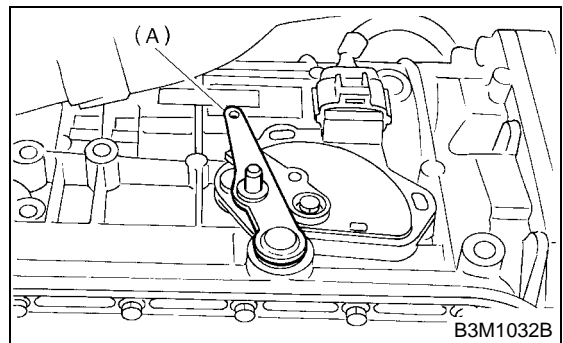

(A) Range select lever

# INHIBITOR SWITCH

## AUTOMATIC TRANSMISSION

12) Remove inhibitor switch from transmission.

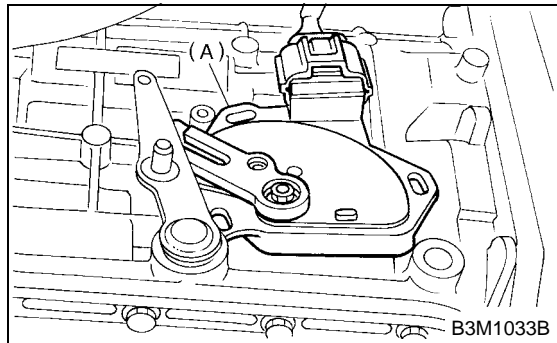

(A) Inhibitor switch

13) Disconnect inhibitor switch harness from inhibitor switch.

### D: INSTALLATION

1) Connect inhibitor switch harness to inhibitor switch.

2) Install inhibitor switch to transmission case.

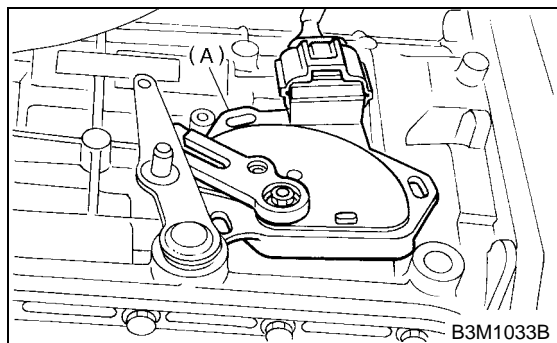

(A) Inhibitor switch

3) Move range select lever to neutral position.

4) Using ST, tighten bolts of inhibitor switch.

ST 499267300 STOPPER PIN

**Tightening torque:**

**3.4 N·m (0.35 kgf·m, 2.5 ft·lb)**

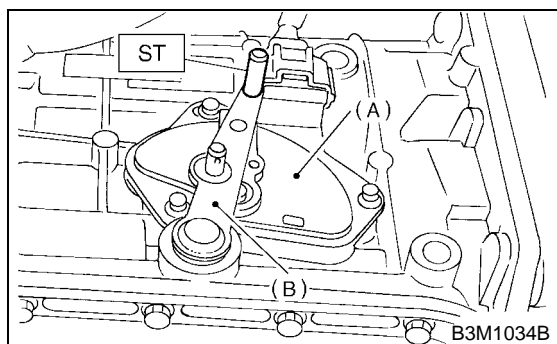

(A) Inhibitor switch

(B) Range select lever

5) Install select cable to range select lever.

6) Install plate assembly to transmission.

**Tightening torque:**

**T: 24.5 N·m (2.50 kgf·m, 18.1 ft·lb)**

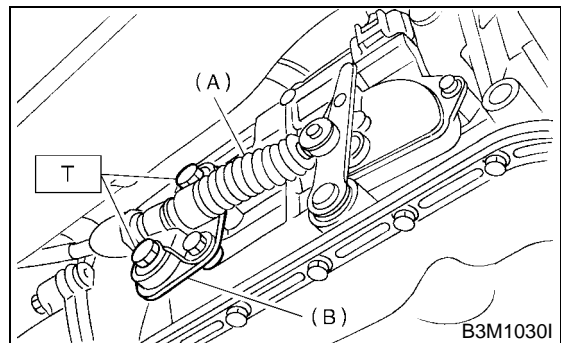

(A) Select cable

(B) Plate ASSY

7) Install snap pin to range select lever.

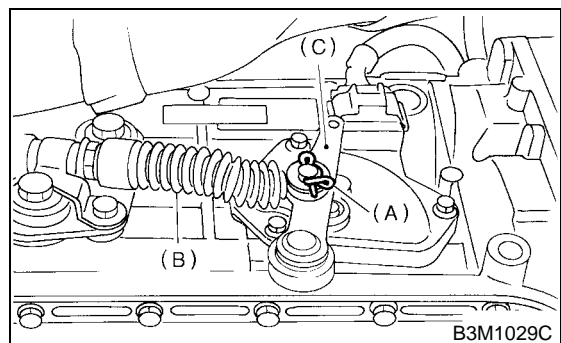

(A) Snap ring

(B) Select cable

(C) Range select lever

8) Install front exhaust pipe with center exhaust pipe.

<Ref. to EX(SOHC)-8, INSTALLATION, Front Exhaust Pipe.> or <Ref. to EX(SOHCw/oOBD)-10, INSTALLATION, Front Exhaust Pipe.>

9) Lower the vehicle.

10) Install inhibitor switch connector from stay.

11) Connect inhibitor switch connector.

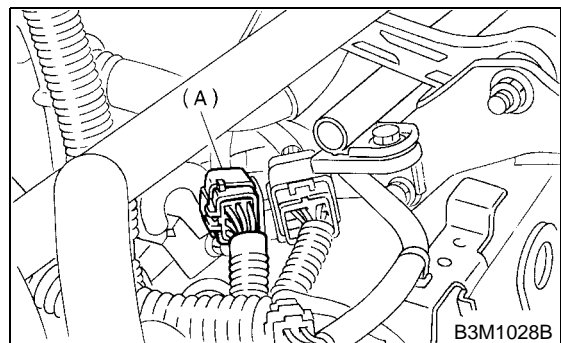

(A) Inhibitor switch

12) Install air intake duct and cleaner case.

## 13. Front Vehicle Speed Sensor

### A: REMOVAL

- 1) Set up the vehicle on the lift.
- 2) Disconnect battery ground terminal.

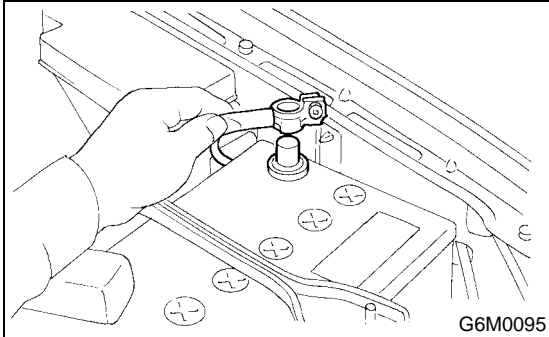

- 3) Disconnect transmission connector.

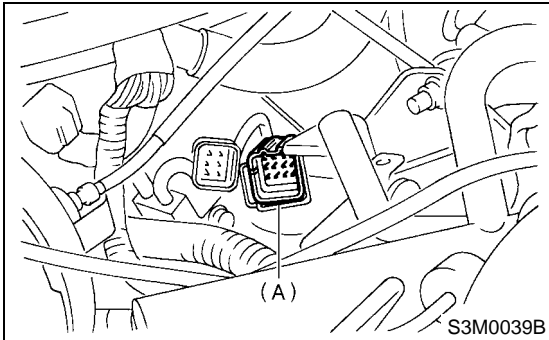

(A) Transmission connector

- 4) Remove the transmission connector from stay.
- 5) Lift-up the vehicle.
- 6) Clean transmission exterior.
- 7) Drain ATF completely.

#### NOTE:

Tighten ATF drain plug after draining ATF.

#### Tightening torque:

**25 N·m (2.5 kgf-m, 18.1 ft-lb)**

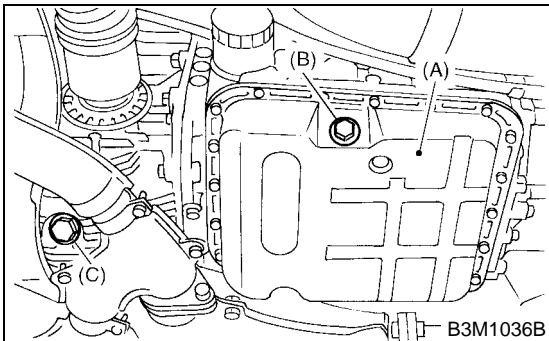

- (A) Oil pan
- (B) Drain plug
- (C) Differential oil drain plug

- 8) Remove front, center, exhaust pipes and muffler. With OBD

<Ref. to EX(SOHC)-7, REMOVAL, Front Exhaust Pipe.>, <Ref. to EX(SOHC)-11, REMOVAL, Rear Exhaust Pipe.> and <Ref. to EX(SOHC)-12, REMOVAL, Muffler.>

Without OBD

<Ref. to EX(SOHCw/oOBD)-9, REMOVAL, Front Exhaust Pipe.>, <Ref. to EX(SOHCw/oOBD)-13, REMOVAL, Rear Exhaust Pipe.> and <Ref. to EX(SOHCw/oOBD)-14, REMOVAL, Muffler.>

- 9) Remove the shield cover.

- 10) Remove the propeller shaft. <Ref. to DS-16, REMOVAL, Propeller Shaft.>

- 11) Place transmission jack under transmission.

#### CAUTION:

• Make sure that the support plates of transmission jack don't touch the oil pan.

- 12) Remove the transmission rear crossmember bolts.

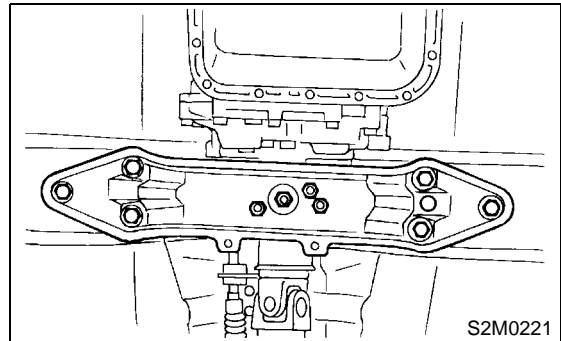

- 13) Lower the AT jack.

#### NOTE:

Do not separate the AT jack and transmission.

- 14) Remove the oil cooler outlet pipe.

#### CAUTION:

When removing outlet pipe, be careful not to lose balls and springs used with retaining screws.



# FRONT VEHICLE SPEED SENSOR

## AUTOMATIC TRANSMISSION

15) Remove front and rear vehicle speed sensor and torque converter turbine speed sensor.

• **Front vehicle speed sensor and torque converter turbine speed sensor**

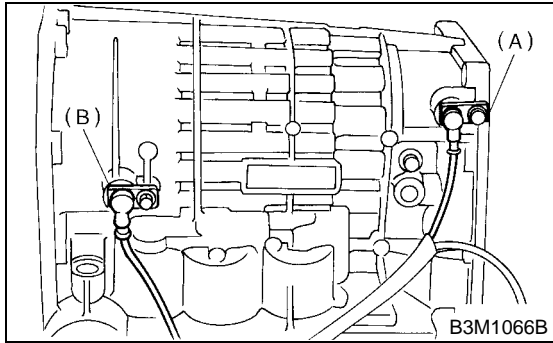

- (A) Front vehicle speed sensor
- (B) Torque converter turbine speed sensor

• **Rear vehicle speed sensor**

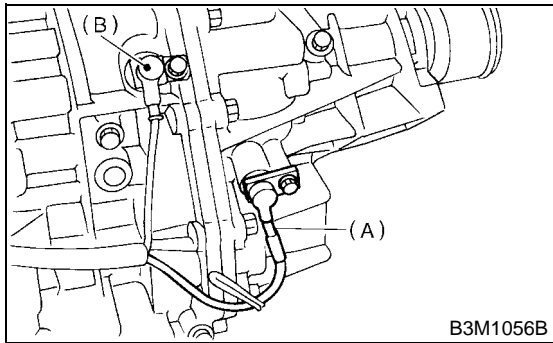

- (A) Rear vehicle speed sensor
- (B) Front vehicle speed sensor

16) Remove oil pan.

17) Disconnect duty solenoids and ATF temperature sensor connectors. Remove connectors from clip and disconnect connectors at 9 places.

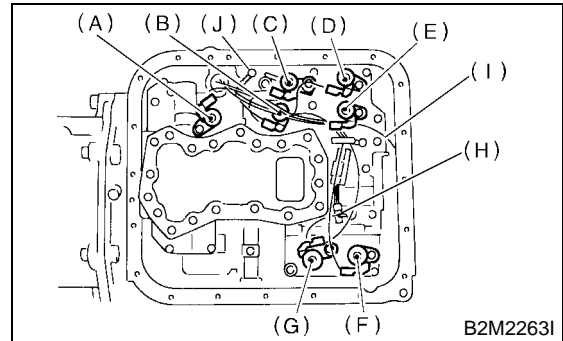

- (A) Lock-up duty solenoid (Blue)
- (B) Low clutch timing solenoid (Gray)
- (C) Line pressure duty solenoid (Red)
- (D) Shift solenoid 2 (Yellow)
- (E) Shift solenoid 1 (Green)
- (F) 2-4 brake timing solenoid (Black)
- (G) 2-4 brake duty solenoid (Red)
- (H) ATF temperature sensor
- (I) Transfer duty solenoid (Brown)
- (J) Transmission ground

18) Remove harness assembly.

## B: INSTALLATION

1) Pass the harness assembly through the hole in the transmission case.

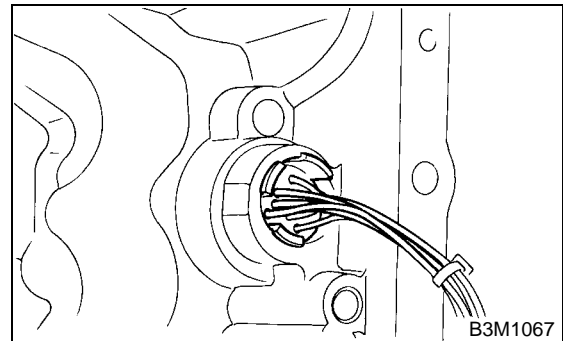

# FRONT VEHICLE SPEED SENSOR

AUTOMATIC TRANSMISSION

- 2) Connect harness connectors at 9 places. Connect connectors of same color, and secure connectors to valve body using clips.

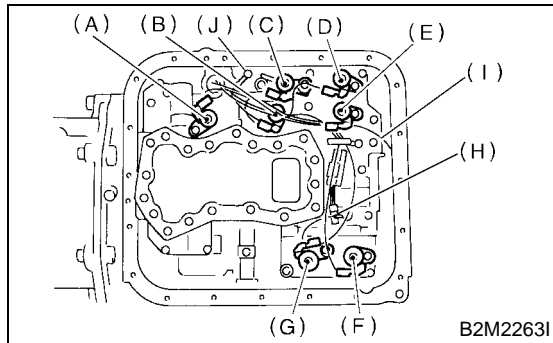

- (A) Lock-up duty solenoid (Blue)
- (B) Low clutch timing solenoid (Gray)
- (C) Line pressure duty solenoid (Red)
- (D) Shift solenoid 2 (Yellow)
- (E) Shift solenoid 1 (Green)
- (F) 2-4 brake timing solenoid (Black)
- (G) 2-4 brake duty solenoid (Red)
- (H) ATF temperature sensor
- (I) Transfer duty solenoid (Brown)
- (J) Transmission ground

- 3) Apply proper amount of liquid gasket to the entire oil pan mating surface.

**Fluid packing:**  
**Three Bond 1217B**

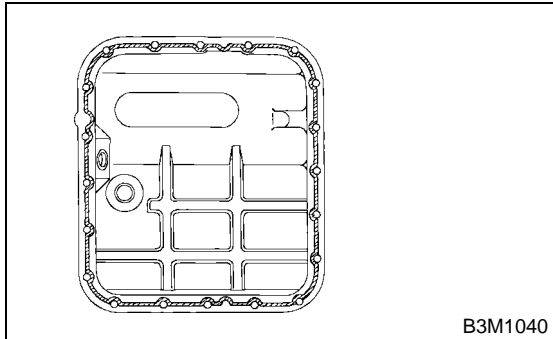

- 4) Install the oil pan.

**Tightening torque:**  
**25 N·m (2.5 kgf-m, 18.1 ft-lb)**

- 5) Install the front and rear vehicle speed sensor, and also the torque converter turbine speed sensor, and then fasten the harness.

**Tightening torque:**  
**7 N·m (0.7 kgf-m, 5.1 ft-lb)**

- 6) Install oil cooler outlet pipe.

**CAUTION:**  
**Be sure to use a new aluminum washer.**

**Tightening torque:**  
**25 N·m (2.5 kgf-m, 18.1 ft-lb)**

- 7) Install transmission rear crossmember bolts.

**Tightening torque:**  
**75 N·m (7.6 kgf-m, 55 ft-lb)**

- 8) Install propeller shaft. <Ref. to DS-17, INSTALLATION, Propeller Shaft.>

- 9) Install shield cover.

- 10) Install front, center, rear exhaust pipes and muffler.

With OBD

<Ref. to EX(SOHC)-8, INSTALLATION, Front Exhaust Pipe.> and <Ref. to EX(SOHC)-11, INSTALLATION, Rear Exhaust Pipe.> and <Ref. to EX(SOHC)-12, INSTALLATION, Muffler.>

Without OBD

<Ref. to EX(SOHCw/oOBD)-10, INSTALLATION, Front Exhaust Pipe.>, <Ref. to EX(SOHCw/oOBD)-13, INSTALLATION, Rear Exhaust Pipe.> and <Ref. to EX(SOHCw/oOBD)-14, INSTALLATION, Muffler.>

- 11) Lower the vehicle.

- 12) Install the transmission connector to the stay.

- 13) Install air intake duct and air cleaner case.

### 14.Rear Vehicle Speed Sensor

#### **A: REMOVAL**

When removing the rear vehicle speed sensor, refer to "Front Vehicle Speed Sensor." <Ref. to AT-31, REMOVAL, Front Vehicle Speed Sensor.>

#### **B: INSTALLATION**

When installing the rear vehicle speed sensor, refer to "Front Vehicle Speed Sensor." <Ref. to AT-32, INSTALLATION, Front Vehicle Speed Sensor.>

## 15. Torque Converter Turbine Speed Sensor

### A: REMOVAL

When removing the torque converter turbine speed sensor, refer to "Front Vehicle Speed Sensor."  
<Ref. to AT-31, REMOVAL, Front Vehicle Speed Sensor.>

### B: INSTALLATION

When installing the torque converter turbine speed sensor, refer to "Front Vehicle Speed Sensor."  
<Ref. to AT-32, INSTALLATION, Front Vehicle Speed Sensor.>

# CONTROL VALVE BODY

## AUTOMATIC TRANSMISSION

### 16. Control Valve Body

#### A: REMOVAL

- 1) Lift-up the vehicle.
- 2) Clean transmission exterior.
- 3) Drain ATF completely.

#### NOTE:

Tighten ATF drain plug after draining ATF.

#### Tightening torque:

**25 N·m (2.5 kgf-m, 18.1 ft-lb)**

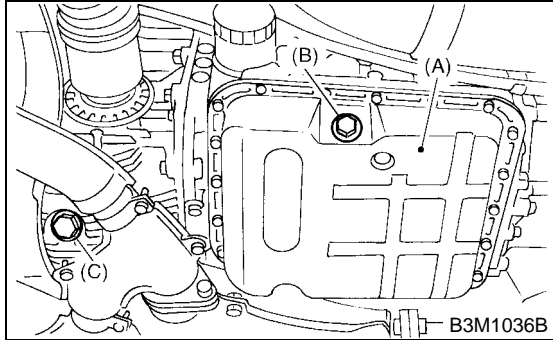

- (A) Oil pan
- (B) Drain plug
- (C) Differential oil drain plug

- 4) Remove the oil pan.

#### NOTE:

- Remove and clean the magnet.
- Remove the old gasket on the oil pan and transmission case completely.

- 5) Disconnect duty solenoids and ATF temperature sensor connectors. Remove connectors from clip and disconnect connectors.

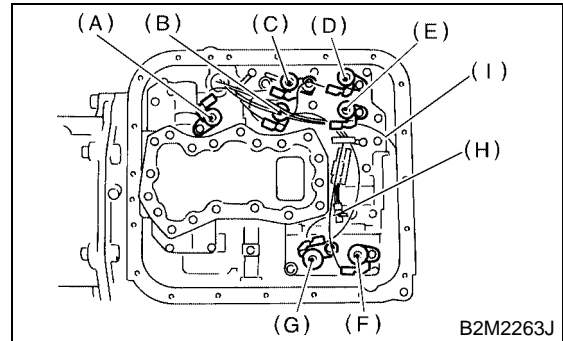

- (A) Lock-up duty solenoid (Blue)
- (B) Low clutch timing solenoid (Gray)
- (C) Line pressure duty solenoid (Red)
- (D) Shift solenoid 2 (Yellow)
- (E) Shift solenoid 1 (Green)
- (F) 2-4 brake timing solenoid (Black)
- (G) 2-4 brake duty solenoid (Red)
- (H) ATF temperature sensor
- (I) Transfer duty solenoid (Brown)

- 6) Remove the control valve. When removing control valve body, be careful not to interfere with transfer duty solenoid wiring

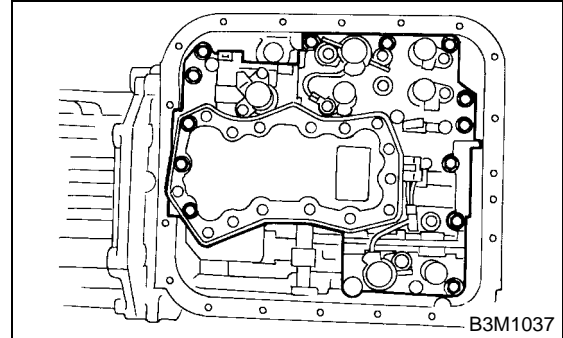

## B: INSTALLATION

- 1) Set the range select lever in "N" position.
- 2) Install the control valve and ground earth connectors.

### Tightening torque:

**8 N·m (0.8 kgf·m, 5.8 ft·lb)**

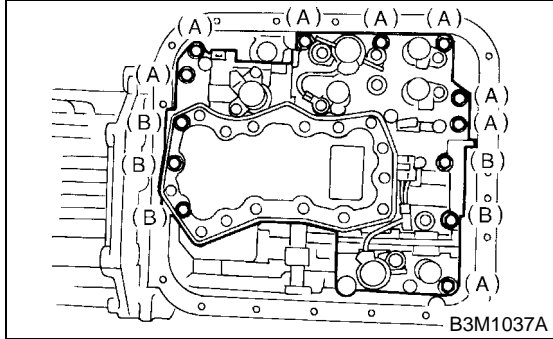

- (A) Short bolts
- (B) Long bolts

- 3) Connect all connector.

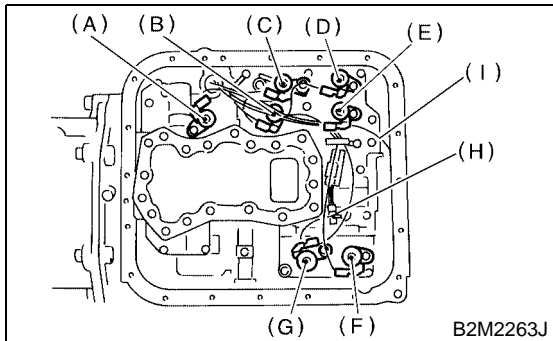

- (A) Lock-up duty solenoid (Blue)
- (B) Low clutch timing solenoid (Gray)
- (C) Line pressure duty solenoid (Red)
- (D) Shift solenoid 2 (Yellow)
- (E) Shift solenoid 1 (Green)
- (F) 2-4 brake timing solenoid (Black)
- (G) 2-4 brake duty solenoid (Red)
- (H) ATF temperature sensor
- (I) Transfer duty solenoid (Brown)

- 4) Attach the magnet at the specified position.

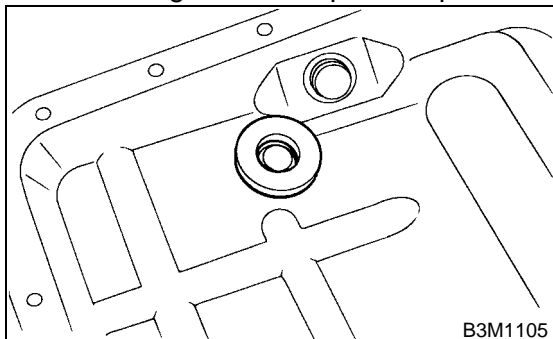

- 5) Apply proper amount of liquid gasket to the entire oil pan mating surface.

### Fluid packing:

**Tree Bond 1217B**

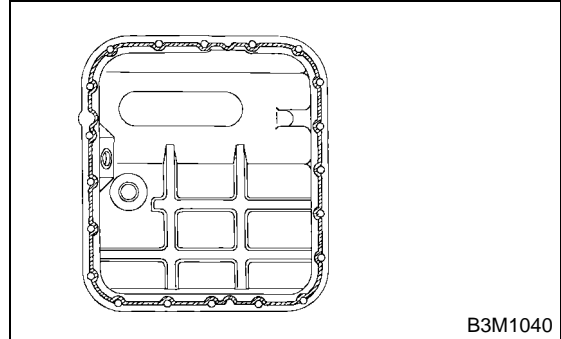

- 6) Install the oil pan.

### Tightening torque:

**4.9 N·m (0.5 kgf·m, 3.6 ft·lb)**

- 7) Pour ATF into the oil charge pipe.

### Recommended fluid:

**Dexron III type automatic transmission fluid**

### Fluid capacity:

**1.6 L models:**

**8.0 — 8.3 ℓ (8.5 — 8.8 US qt, 7.0 — 7.3 Imp qt)**

**2.0 L model:**

**8.4 — 8.7 ℓ (8.9 — 9.2 US qt, 7.4 — 7.7 Imp qt)**

- 8) Check the level of the ATF.

<Ref. to AT-9, Automatic Transmission Fluid.>

## C: DISASSEMBLY

Refer to "AUTOMATIC TRANSMISSION" <Pub. No. G0853ZE> a separate publication.

## D: ASSEMBLY

Refer to "AUTOMATIC TRANSMISSION" <Pub. No. G0853ZE> a separate publication.

## E: INSPECTION

Refer to "AUTOMATIC TRANSMISSION" <Pub. No. G0853ZE> a separate publication.

## 17. Shift Solenoids, Duty Solenoids and ATF Temperature Sensor

### A: REMOVAL

- 1) Lift-up the vehicle.
- 2) Clean transmission exterior.
- 3) Drain ATF completely.

**NOTE:**

Tighten ATF drain plug after draining ATF.

**Tightening torque:**

**25 N·m (2.5 kgf-m, 18.1 ft-lb)**

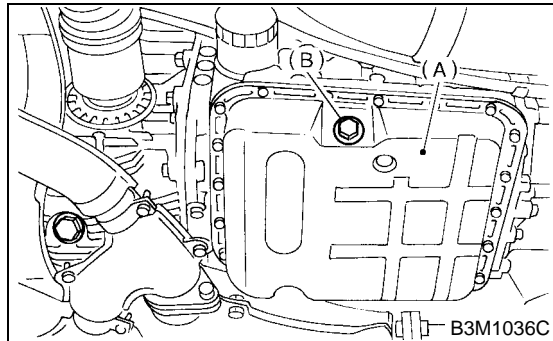

- (A) Oil pan
- (B) Drain plug

- 4) Remove oil pan.
- 5) Disconnect solenoid and sensor connectors. Remove connectors from clip and disconnect connectors.

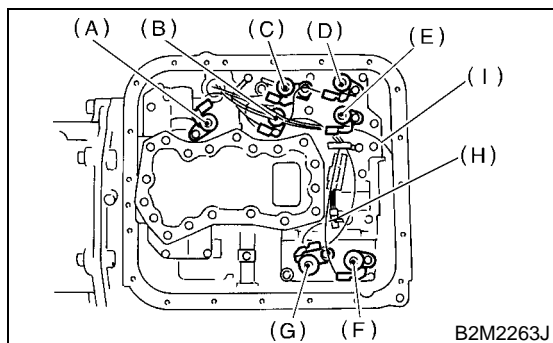

- (A) Lock-up duty solenoid (Blue)
- (B) Low clutch timing solenoid (Gray)
- (C) Line pressure duty solenoid (Red)
- (D) Shift solenoid 2 (Yellow)
- (E) Shift solenoid 1 (Green)
- (F) 2-4 brake timing solenoid (Black)
- (G) 2-4 brake duty solenoid (Red)
- (H) ATF temperature sensor
- (I) Transfer duty solenoid (Brown)

- 6) Remove solenoids, duty solenoids and ATF temperature sensor.

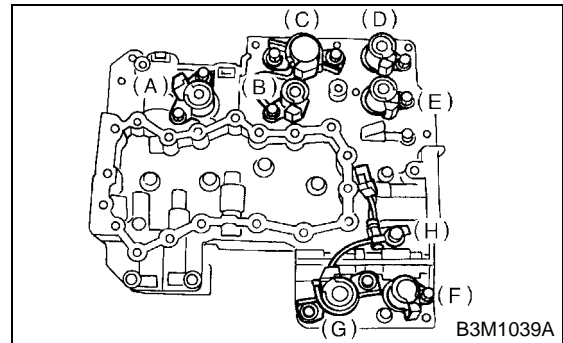

- (A) Lock-up duty solenoid (Blue)
- (B) Low clutch timing solenoid (Gray)
- (C) Line pressure duty solenoid (Red)
- (D) Shift solenoid 2 (Yellow)
- (E) Shift solenoid 1 (Green)
- (F) 2-4 brake timing solenoid (Black)
- (G) 2-4 brake duty solenoid (Red)
- (H) ATF temperature sensor

### 1. TRANSFER DUTY SOLENOID AND TRANSFER VALVE BODY

- 1) Set up the vehicle on the lift.
- 2) Disconnect battery ground terminal.
- 3) Remove air intake duct. <Ref. to IN(SOHC)-7, REMOVAL, Air Intake Duct.>
- 4) Remove air cleaner case. <Ref. to IN(SOHC)-6, REMOVAL, Air Cleaner Case.>
- 5) Remove pitching stopper.

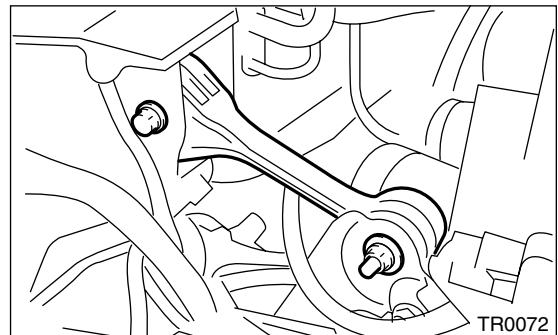

- 6) Remove front exhaust pipe with center exhaust pipe.  
With OBD  
<Ref. to EX(SOHC)-7, REMOVAL, Front Exhaust Pipe.>  
Without OBD  
<Ref. to EX(SOHCw/oOBD)-9, REMOVAL, Front Exhaust Pipe.>

# SHIFT SOLENOIDS, DUTY SOLENOIDS AND ATF TEMPERATURE SENSOR

## AUTOMATIC TRANSMISSION

7) Raise vehicle and drain ATF.

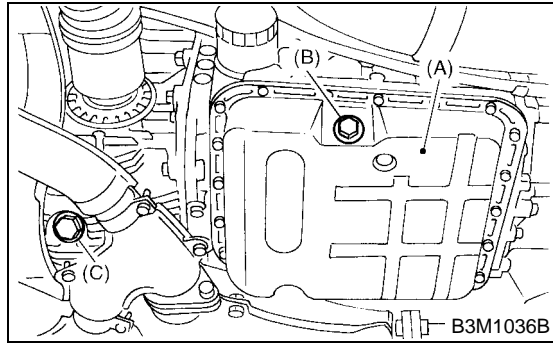

- (A) Oil pan
- (B) Drain plug
- (C) Defferential oil drain plug

8) Remove heat shield cover.

9) Remove propeller shaft. <Ref. to DS-16, REMOVAL, Propeller Shaft.>

10) Remove rear crossmember.

- (1) Support transmission using a transmission jack and raise slightly.
- (2) Remove bolts and nuts as shown in Figure.

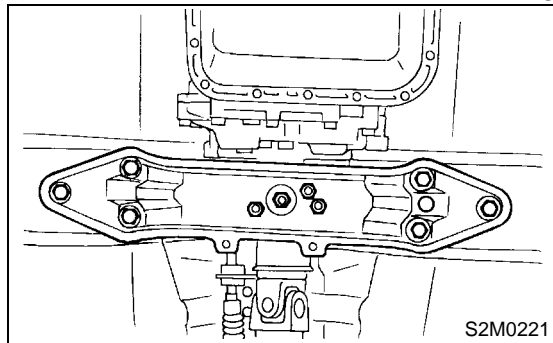

11) Remove rear vehicle speed sensor.

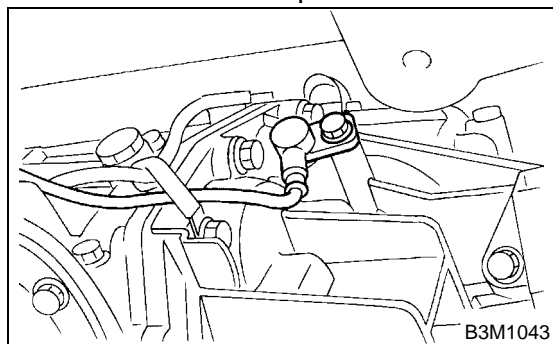

12) Remove select cable nut.

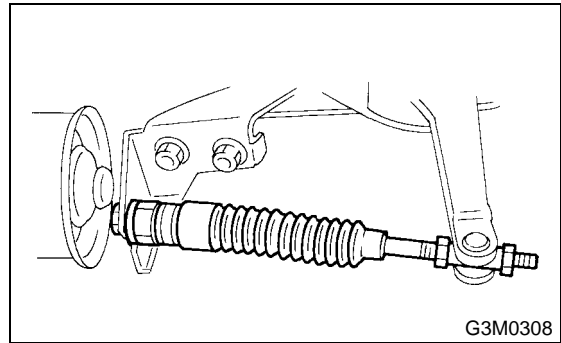

13) Move gear select cable so that extension bolts can be removed.

14) Remove bolts.

15) Remove extension case.

NOTE:

Use a container to catch oil flowing from extension.

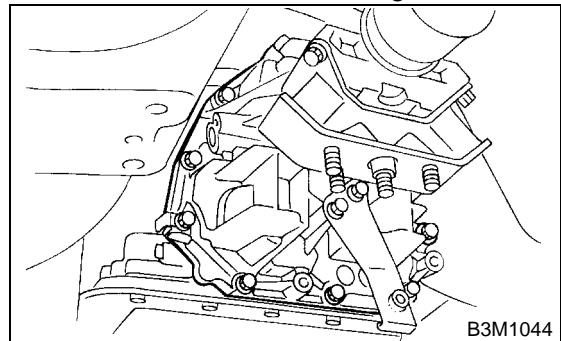

16) Disconnect transfer duty solenoid connector.

17) Remove transfer duty solenoid and transfer valve body.

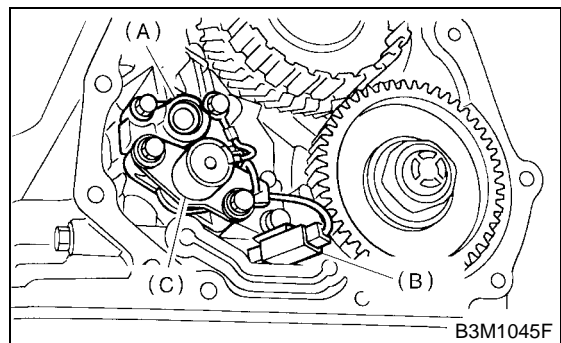

- (A) Transfer valve body
- (B) Transfer duty solenoid connector
- (C) Transfer duty solenoid



# SHIFT SOLENOIDS, DUTY SOLENOIDS AND ATF TEMPERATURE SENSOR

## AUTOMATIC TRANSMISSION

### B: INSTALLATION

1) Install solenoids and ATF temperature sensor.

#### Tightening torque:

**T: 8 N·m (0.8 kgf·m, 5.8 ft·lb)**

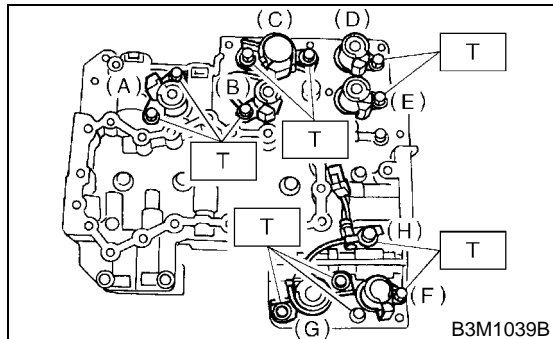

- (A) Lock-up duty solenoid (Blue)
- (B) Low clutch timing solenoid (Gray)
- (C) Line pressure duty solenoid (Red)
- (D) Shift solenoid 2 (Yellow)
- (E) Shift solenoid 1 (Green)
- (F) 2-4 brake timing solenoid (Black)
- (G) 2-4 brake duty solenoid (Red)
- (H) ATF temperature sensor

2) Connect harness connectors.

Connect connectors of same color, and secure connectors to valve body using clips.

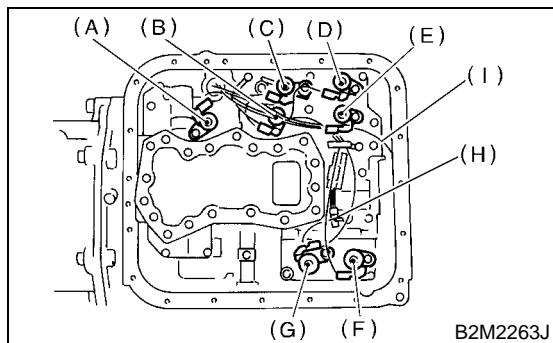

- (A) Lock-up duty solenoid (Blue)
- (B) Low clutch timing solenoid (Gray)
- (C) Line pressure duty solenoid (Red)
- (D) Shift solenoid 2 (Yellow)
- (E) Shift solenoid 1 (Green)
- (F) 2-4 brake timing solenoid (Black)
- (G) 2-4 brake duty solenoid (Red)
- (H) ATF temperature sensor
- (I) Transfer duty solenoid (Brown)

3) Apply proper amount of liquid gasket to the entire oil pan mating surface.

#### Fluid packing:

**Tree Bond 1217B**

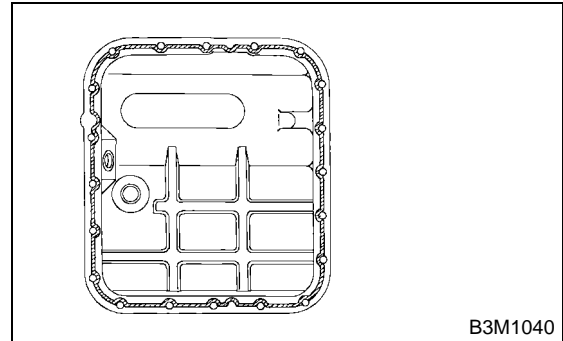

4) Install oil pan.

#### Tightening torque:

**4.9 N·m (0.50 kgf·m, 3.6 ft·lb)**

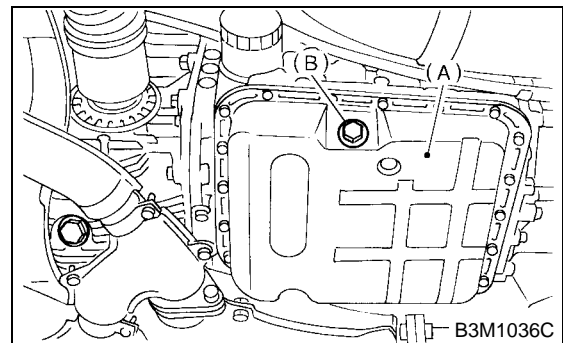

- (A) Oil pan
- (B) Drain plug

5) Fill ATF up to the middle of the "COLD" side on level gauge by using the gauge hole.

#### Recommended fluid:

**Dexron III type automatic transmission fluid**

#### Fluid capacity:

**1.6 L model:**

**8.0 — 8.3 ℓ (8.5 — 8.8 US qt, 7.0 — 7.3 Imp qt)**

**2.0 L model:**

**8.4 — 8.7 ℓ (8.9 — 9.2 US qt, 7.4 — 7.7 Imp qt)**

6) Check the ATF level. <Ref. to AT-9, Automatic Transmission Fluid.>

# SHIFT SOLENOIDS, DUTY SOLENOIDS AND ATF TEMPERATURE SENSOR

AUTOMATIC TRANSMISSION

## 1. TRANSFER DUTY SOLENOID AND TRANSFER VALVE BODY

1) Install transfer duty solenoid and transfer valve body.

- (1) Install transfer duty solenoid and transfer valve body.

### Tightening torque:

**T: 8 N·m (0.8 kg-m, 5.8 ft-lb)**

- (2) Connect transfer duty solenoid connector.

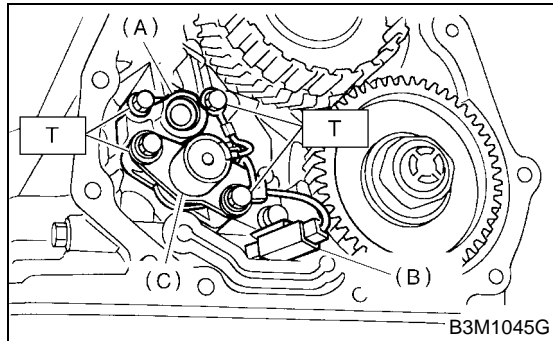

- (A) Transfer valve body
- (B) Transfer duty solenoid connector
- (C) Transfer duty solenoid

2) Install extension case to transmission case.

- (1) Tighten 11 bolts.

### Tightening torque:

**25 N·m (2.5 kg-m, 18.1 ft-lb)**

- (2) Adjust the select cable. <Ref. to CS-10, ADJUSTMENT, Select Cable.>

3) Install rear vehicle speed sensor.

### Tightening torque:

**T: 7 N·m (0.7 kg-m, 5.1 ft-lb)**

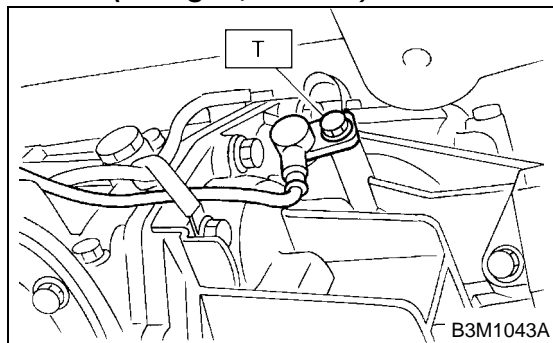

4) Install rear crossmember.

- (1) Tighten bolts.

### Tightening torque:

**T1: 35 N·m (3.6 kg-m, 26 ft-lb)**

**T2: 70 N·m (7.1 kg-m, 51.4 ft-lb)**

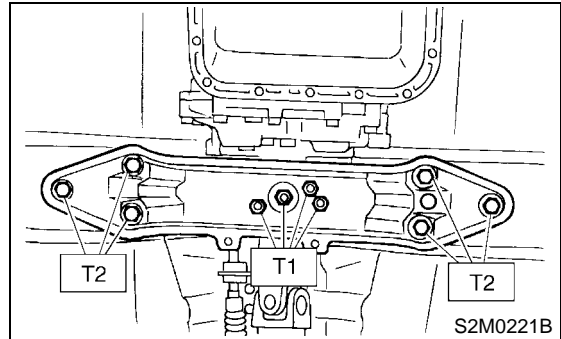

- (2) Lower and remove transmission jack.

5) Install propeller shaft. <Ref. to DS-17, INSTALLATION, Propeller Shaft.>

6) Install front exhaust pipe and center exhaust pipe.

7) Lower and remove jack.

8) Connect the following parts:

- (1) Oxygen sensor connector
- (2) Transmission harness connector

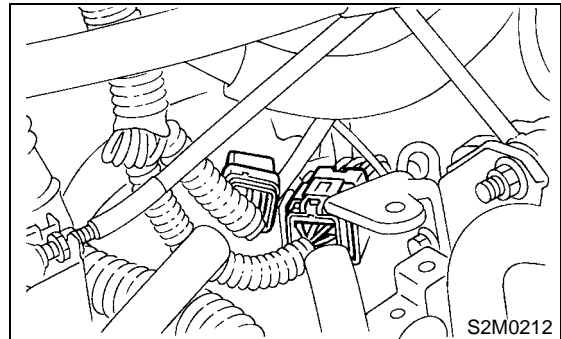

9) Install pitching stopper.

### Tightening torque:

**T1: 49 N·m (5.0 kg-m, 36.2 ft-lb)**

**T2: 57 N·m (5.8 kg-m, 42 ft-lb)**

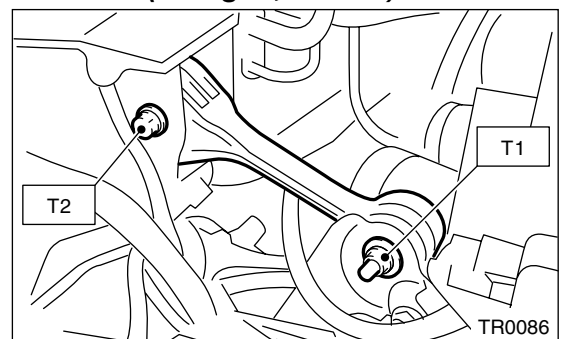

10) Install air cleaner case and duct.

# SHIFT SOLENOIDS, DUTY SOLENOIDS AND ATF TEMPERATURE SENSOR

## AUTOMATIC TRANSMISSION

---

11) Fill ATF up to the middle of the "COLD" side on level gauge by using the gauge hole.

***Recommended fluid:***

***Dexron III type automatic transmission fluid***

***Fluid capacity:***

***1.6 L model; 8.0 - 8.3 L (8.5 - 8.8 US qt, 7.0 - 7.3 Imp qt)***

***2.0 L model; 8.4 - 8.7 L (8.9 - 9.2 US qt, 7.4 - 7.3 Imp qt)***

12) Check the ATF level. <Ref. to AT-9, Automatic Transmission Fluid.>

## 18.ATF Filter

### A: REMOVAL

NOTE:

The ATF filter is maintenance free.

- 1) Lift-up the vehicle.
- 2) Using ST, remove ATF filter.

ST 498545400 OIL FILTER WRENCH

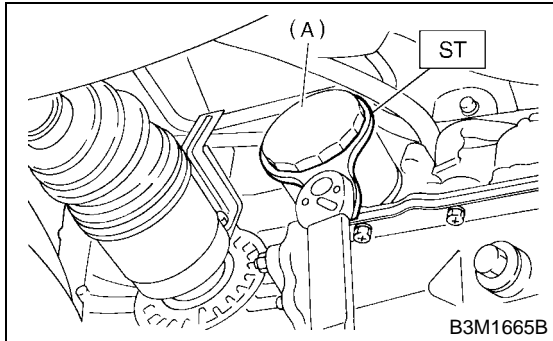

(A) ATF filter

- 3) Get new ATF filter and apply a thin coat of ATF to the oil seal.

### B: INSTALLATION

- 1) Install ATF filter. Turn it by hand, being careful not to damage oil seal.
- 2) Using ST, tighten ATF filter to transmission case. Calculate ATF filter torque specifications using the following formula.

$$T2 = L1 / (L1 + L2) \times T1$$

T1: 14 N·m (1.4 kgf·m, 10.1 ft·lb)

[Required torque setting]

T2: Tightening torque

L1: ST length 0.078 m (3.07 in)

L2: Torque wrench length

Example:

Torque wrench length mm (in)	Tightening torque N·m (kgf·m, ft·lb)
100 (3.94)	6 (0.6, 4.3)
150 (5.91)	5 (0.5, 3.6)
200 (7.87)	4 (0.4, 2.9)
250 (9.84)	3 (0.3, 2.2)

### CAUTION:

**Align ST with torque wrench while tightening ATF filter.**

ST 498545400 OIL FILTER WRENCH

- 3) Add ATF.
- 4) Inspect level of ATF. <Ref. to AT-9, Automatic Transmission Fluid.>

### C: INSPECTION

Replace the part if any defect is found from the inspection.

Check for rust, hole, ATF leaks, and other damage.

# TRANSMISSION CONTROL MODULE (TCM)

AUTOMATIC TRANSMISSION

## 19. Transmission Control Module (TCM)

### A: REMOVAL

- 1) Disconnect battery ground terminal.

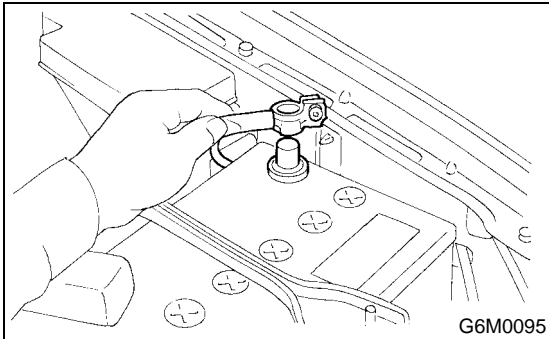

- 2) Remove lower cover and then disconnect connector.

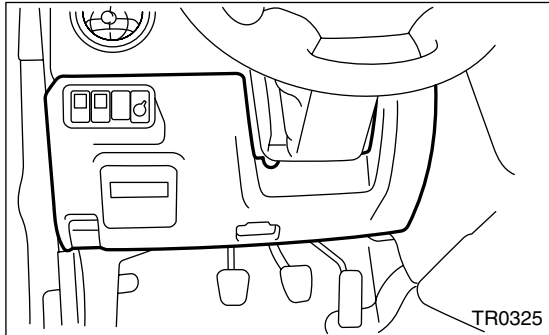

- 3) Disconnect connectors from transmission control module.

#### LHD model

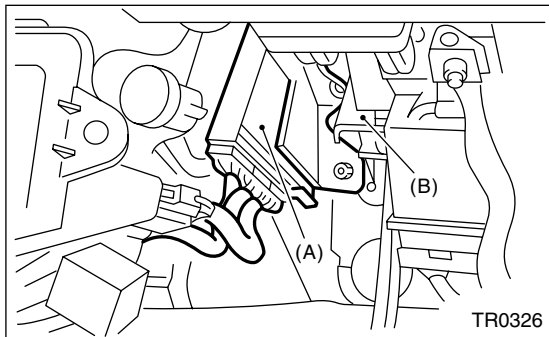

- (A) Transmission control module
- (B) Brake pedal bracket

#### RHD model

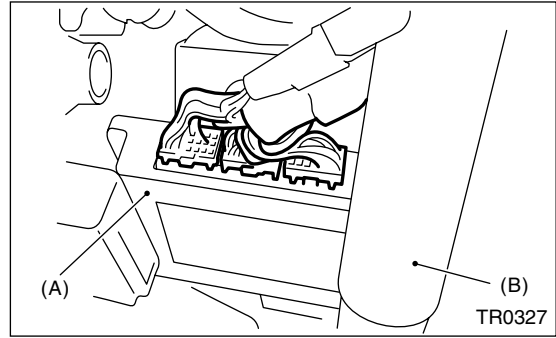

- (A) Transmission control module
- (B) Column shaft

- 4) Remove transmission control module.

### B: INSTALLATION

- 1) Install transmission control module.

#### Tightening torque:

##### LHD model

7.4 N·m (0.75 kgf·m, 5.4 ft·lb)

##### RHD model

25 N·m (2.5 kgf·m, 18.1 ft·lb)

#### LHD model

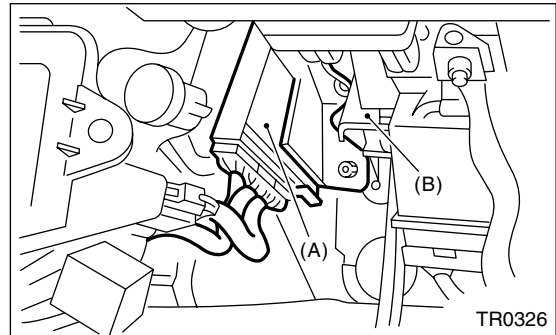

- (A) Transmission control module
- (B) Brake pedal bracket

#### RHD model

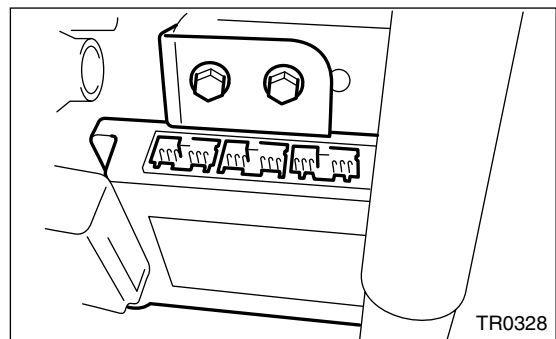

- (A) Transmission control module
- (B) Column shaft

- 2) Connect connectors to transmission control module.

- 3) Install in the reverse order of removal.

## 20.ATF Cooler Pipe and Hose

### A: REMOVAL

- 1) Set the vehicle on the lift.
- 2) Remove battery and washer tank.
- 3) Lift-up the vehicle.
- 4) Remove the under cover.
- 5) Disconnect ATF cooler hose from radiator.

**NOTE:**

- Do not remove with a screwdriver or other pointed tools.
- When the hose is difficult to remove, wrap a shop cloth around the hose to protect it. Turn it with pliers, and then pull directly out with your hand.

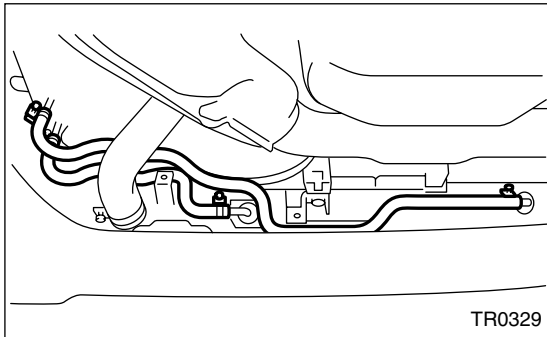

- 6) Disconnect ATF cooler hoses from pipes.

**NOTE:**

- Do not remove with a screwdriver or other pointed tools.
- When the hose is difficult to remove, wrap a shop cloth around the hose to protect it. Turn it with pliers, and then pull directly out with your hand.

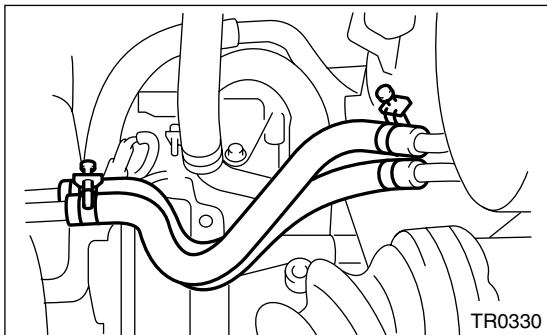

- 7) Remove ATF cooler pipe from frame.

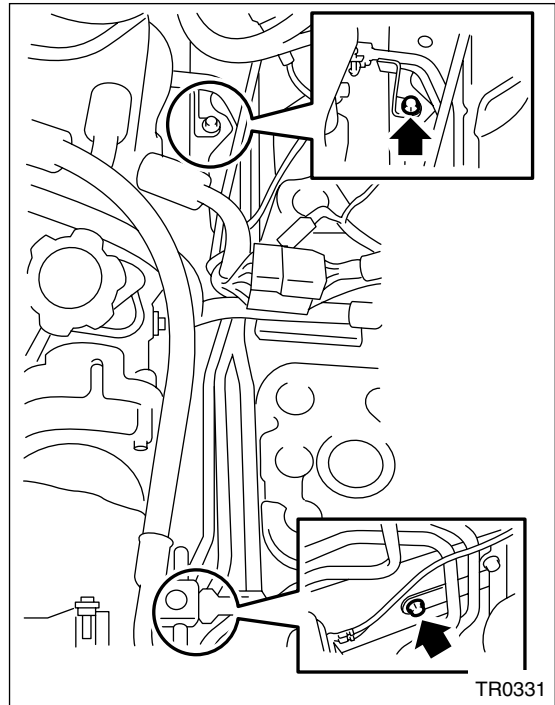

- 8) Remove the oil cooler inlet and outlet pipes.

**CAUTION:**

**When removing outlet pipe, be careful not to lose ball and spring used with retaining screw.**

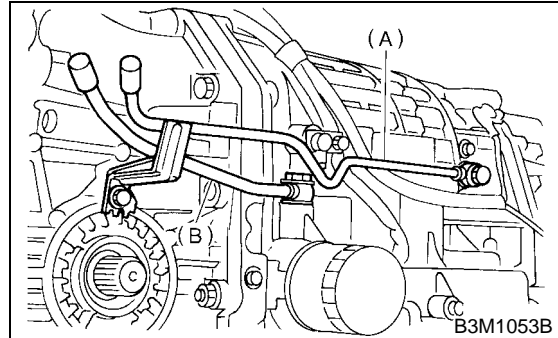

- (A) Inlet pipe
- (B) Outlet pipe

# ATF COOLER PIPE AND HOSE

## AUTOMATIC TRANSMISSION

### B: INSTALLATION

1) Install the oil cooler outlet and inlet pipes.

#### CAUTION:

Be sure to use a new aluminum washer.

#### Tightening torque:

T1: 44 N·m (4.5 kgf-m, 32.5 ft-lb)

T2: 25 N·m (2.5 kgf-m, 18.1 ft-lb)

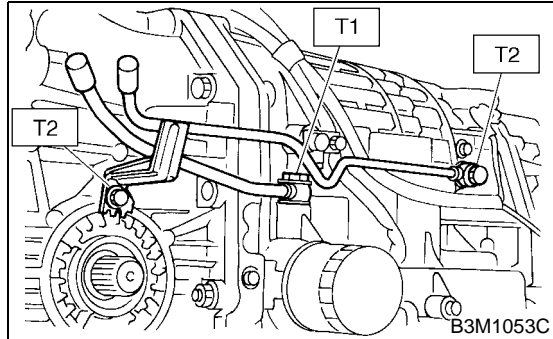

- (A) Inlet pipe
- (B) Outlet pipe

2) Install ATF cooler pipe to frame.

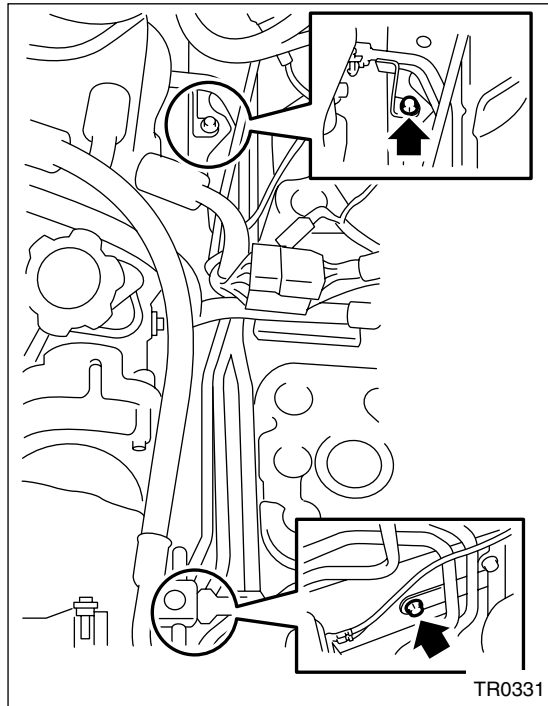

3) Connect ATF cooler hose to pipe transmission side.

#### NOTE:

- Install so that the hose is not folded over, excessively bent, or twisted.
- Be careful to insert the hose to the specified position.

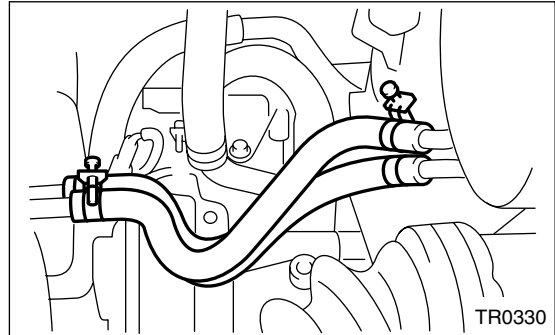

4) Connect ATF cooler hose to pipe of radiator side.

#### NOTE:

- Install so that the hose is not folded over, excessively bent, or twisted.
- Be careful to insert the hose to the specified position.

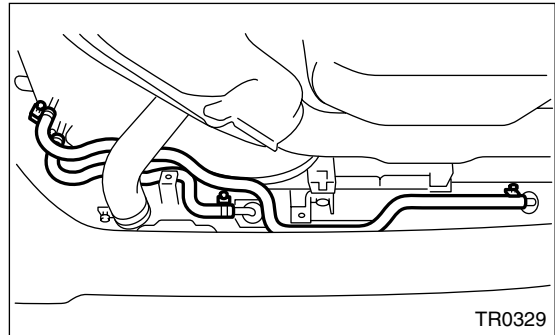

5) Install the under cover.

6) Install battery and washer tank.

7) Fill ATF. <Ref. to AT-9, Automatic Transmission Fluid.>

#### NOTE:

Make sure there are no ATF leaks in joints between the transmission, radiator, pipes, and hoses.

## **C: INSPECTION**

Repair or replace any defective hoses, pipes, clamps, and washers found from the inspection below.

- 1) Check for ATF leaks in joints between the transmission, radiator, pipes, and hoses.
- 2) Check for deformed clamps.
- 3) Lightly bend the hose and check for cracks in the surface and other damage.
- 4) Pinch the hose with your fingers and check for poor elasticity. Also check for poor elasticity in the parts where the clamp was by pressing with your fingernail.
- 5) Check for peeling, cracks, and deformation at the tip of the hose.



